

On the movement/(anti)agreement correlation in Romance and Mayan

Elise Newman, MIT*

September 10, 2020

Abstract

General consensus in the syntactic literature assumes that a causal relationship between Agree and internal Merge is responsible for movement/agreement correlations in many languages. I argue against this approach with evidence from Romance Past Participle Agreement (PPA) and Mayan Agent Focus constructions (which show a movement/agreement and movement/anti-agreement phenomenon respectively). On the proposed analysis, Merge (internal and external) and Agree are not causally related, but are ordered according to economy conditions on the derivation, which are sensitive to the features of the functional projections in a given clause and the arguments they introduce (Longenbaugh, 2019, with insights from Müller 2010). Following Longenbaugh (2019), the time at which the subject is externally merged affects case on the object in Romance, which affects whether or not it is accessible to Agree (Bobaljik, 2008; Preminger, 2014). The result is a movement-agreement correlation: in situ objects are inaccessible to Agree, but A-moved ones are accessible. I propose that Mayan Agent Focus instantiates a movement/anti-agreement correlation for similar reasons. The timing of external Merge is predicted to be different for transitive clauses than for subject wh-questions in high absolutive Mayan languages. The resulting structure of each generates a different agreement alignment, the latter of which makes the object a more local goal for the probe that would normally target the subject. The result is an anti-agreement correlation: wh-movement of the subject results in a derivation in which the subject is a non-local φ -goal, so its features are not cross-referenced on the verb.

1 Introduction

A pervasive puzzle throughout the syntactic literature is how best to understand the interaction between MERGE and AGREE. In languages with movement/agreement correlations, it was once thought that movement was a precondition for Agree, that Agree was an intrinsically Spec-head phenomenon (Kayne, 1989; Pollock, 1989; Chomsky, 1991, 1993). More recent work has argued against this idea with a multitude of data from various languages, which show Agree

*I want to thank Jessica Coon, Michael Yoshitaka Erlewine, Cora Lesure, David Pesetsky, and Norvin Richards for their thorough feedback, patience and guidance on this project. A special thanks goes to Kenyon Branam, who managed to see the potential for this project before I did, and inspired me to work on it. All mistakes are my own.

can happen independently of movement. It has since been common to assume the opposite—that Agree is a precondition for movement (Chomsky, 2000, 2001). Agree feeds movement by searching for elements of the target category and attracting the closest one to the probe.

On this approach, the fact that A-movement is correlated with Agree in many languages is straightforwardly predicted by the theory. However, while this view has been successful for A-movement, the interaction between agreement and \bar{A} -movement is less well understood. Uniformity between A and \bar{A} -movement would demand that Agree of some kind is also a precondition for \bar{A} -movement. However, there are fewer known overt correlations between wh-movement and agreement, and in some languages, the only morphological signature of wh-movement is a *loss* of φ -agreement.

Longenbaugh (2019) offers a different view of the A-movement/agreement correlation, which I will argue is more amenable to the \bar{A} -movement/agreement interaction. On his view, which builds on work by Müller (2010), movement and agreement are not causally related, but are formally dissociated. What makes them appear correlated in A-movement, he proposes, is an economy condition that minimizes the number of distinct operations in a syntactic derivation. He proposes that this amendment to the theory is necessary to account for the distribution of Romance Past Participle Agreement (henceforth PPA), and impacts the order of operations in a derivation more generally.

Romance PPA only cross-references the object when it A-moves, which he proposes is due to the case properties of the relevant constructions, not because Agree feeds movement or vice versa. Constructions in which the object A-moves are constructions in which the object is never marked for case, and is therefore accessible to Agree throughout the entire derivation. Constructions in which the object does not A-move are those in which the object is assigned accusative case, which following Bobaljik (2008); Preminger (2014), among others, is proposed to bleed Agree. This system requires no causality between Move and Agree; it just so happens that constructions in which the object A-moves are those in which it is accessible to the PPA probe.

- (1) *Standard Italian - PPA only occurs when the object A-moves*
- a. Ho mangiat-**o**/***a** **la mela**
have.1.SG eaten-M.SG/***F.SG** the apple.F.SG
“I have eaten the apple.” (D’Alessandro & Roberts 2008)
 - b. **Due ladri** sono entrat-**i**/***o** dalla finestra
two robbers are entered-M.PL/***M.SG** from-the window
“Two robbers entered from the window.” (Belletti 2006: ex.34c)
 - c. **Alcuni sindaci** sono stati arrestat-**i**/***o**
some.M.PL mayors.M.PL are.PL been.M.PL arrested.M.PL/***SG**
“Some mayors were arrested.”

Longenbaugh also shows that wh-movement looks different from A-movement with respect to PPA, not necessarily because A/ \bar{A} -probes have different properties, but because wh-movement doesn’t affect case assignment in the same way. A-movement of an object bleeds accusative case assignment, licensing PPA. \bar{A} -movement, by contrast, is orthogonal to accusative case assignment, and so should not necessarily interact with PPA¹.

¹Except in French, which will be discussed in Section 2.

- (2) *Standard Italian - wh-movement does not license PPA*

Quanti **libri** hai lett-**o**/***i**?
 how.many.M.PL books.M.PL have.3.SG read-M.SG/***M**.PL

“How many books have you read?” (Belletti 2006)

On this system, the timing of case assignment and the satisfaction of features on a head becomes very important for describing these facts. In this paper, I will demonstrate that the spirit of these proposals makes very broad predictions beyond the particular movement/agreement correlation in Romance. I will adopt the central insights of his proposal and show that an alternative version of it offers a natural explanation for anti-agreement effects in subject \bar{A} -extraction in other languages. In particular, I will focus on how this system works for Mayan Agent Focus constructions.

High absolutive Mayan languages show what is known as the *Ergative Extraction Constraint* (henceforth EEC). The agreement alignment of a clause is unaffected by wh-movement of an absolutive argument. However, wh-movement of an *ergative* argument results in special morphology that bleeds φ -agreement with that argument.

- (3) *Q'anjob'al - Transitive clauses include both subject and object agreement*

a. Max-ach y-il-a'.
 ASP-O2S S3S-see-TV

‘She saw you.’ (Coon et al. 2014: 10)

- (4) *Q'anjob'al - Subject \bar{A} -extraction bleeds subject agreement, requires a special morpheme glossed AF*

a. Maktxel max-ach il-**on**-i?
 who PFV-O2S see-AF-ITV

“Who saw you?” (Coon et al. 2014, 213)

The logic of the proposal is that the order of operations in a syntactic derivation has consequences for what arguments are accessible to which φ -probes. In regular transitive clauses, the conditions on Merge and Agree are such that the external argument must be introduced before any other operation applies. It is then assigned ergative case, which is selectively accessible to some φ -probes but not all. This “Merge-first” requirement therefore affects both case alignment and the orientation of arguments, which results in the subject and the object being accessible to different φ -probes. However, when the external argument has additional features, such as wh-features, I propose that those same conditions no longer require it to merge first. This sudden ability of the subject to merge late in subject wh-questions results in all relevant φ -probes targeting the absolutive object, which causes the observed effects on the agreement alignment of the clause.

Multiple agreement with the object is proposed to be constrained by the condition in (5), which rules out multiple exponence of a single argument’s features (c.f. *Kinyalolo’s constraint* (Kinyalolo, 1991), Oxford 2017).

- (5) *Anti-redundancy*: two adjacent φ -probes that cross-reference the same argument must delete the lower probe. Deleted feature bundles get spelled out as an elsewhere form.

In Mayan, I propose that the Agent Focus morpheme is the elsewhere form of the probe that would normally cross-reference a transitive subject. In subject wh-questions, it surfaces because that probe has redundantly agreed with the object instead of the subject. It also incidentally surfaces in anti-passives, by the same logic but for different reasons.

Anti-passives are like subject wh-questions in that they make one argument accessible to multiple φ -probes. While subject wh-questions promote the object, however, anti-passives promote the subject. Subject wh-questions are therefore derivationally distinct from anti-passives, and have different consequences for Agree in general. However, they have in common the fact that both derivations involve redundant agreement with one argument. Redundant agreement is realized as a single exponent of the goal's features plus an elsewhere form.

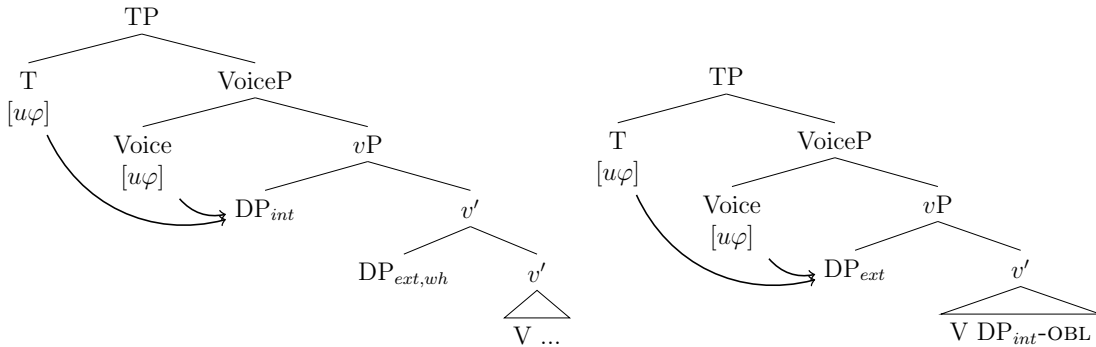

(a) Subject wh-questions have the effect of promoting the object: two probes redundantly agree with it, which is pronounced as one exponent of the object's features plus AF. (b) Anti-passives remove the object as a competitor and make the subject absolutive, which leads to redundant agreement \rightarrow AF.

Figure 1: Subject wh-questions and anti-passives have in common that the highest argument is absolutive, which is accessible to every higher probe, leading to redundant agree.

EEC effects have also been explained in various other ways. One popular line of reasoning proposes that anti-agreement signifies a failure of the ergative subject to undergo normal \bar{A} -movement, either due to properties of the \bar{A} -probe, or accessibility of the goal. I will argue against this treatment. I propose that there is nothing special about wh-movement in these languages per se. The special morphology in subject wh-questions is simply a reflection of where the φ -goals in the clause are, not a reflection of any problem with \bar{A} -moving the subject. In general, I assume wh-movement to be garden variety \bar{A} -movement in the sense that it is non-local, insensitive to the category of the moved element, and targets non-theta positions. In Figure 1a, for example, I assume the wh-subject simply \bar{A} -moves across the object to Spec CP when C is merged.

I also argue against the idea that subject wh-questions are intransitive in these languages. The morphology *appears* intransitive because the object ends up being the most local φ -goal to all of the φ -probes. However, the functional projections in the clausal spine are those of a regular transitive clause, not of an anti-passive clause. This proposal therefore offers a uniform analysis of Mayan transitive clauses and wh-questions, and additionally requires no novel assumptions about \bar{A} -movement.

The structure of the paper is as follows. Section 2 reviews Longenbaugh's observations about the movement/agreement correlation in Romance and argues for a stronger version of

his theory that Merge and Agree are not causally related. Section 3 extends this proposal to Mayan Agent Focus constructions, and shows how this account explains both the basic and special cases of EEC effects. Section 4 offers a theory comparison to other analyses of Mayan EEC effects, and Section 5 offers some parting thoughts on the cross-linguistic viability of the proposal.

2 Longenbaugh 2019

The central puzzle that Longenbaugh investigates is the fact that Past Participle Agreement (PPA) in Romance is sensitive to transitivity. Transitive clauses display no PPA, while passive and unaccusative clauses do. PPA only ever cross-references the internal argument so this generalization can be described as follows: object agreement is blocked by a promoted transitive subject.

(1) Standard Italian

- a. Ho mangiat-**o**/*a la mela
have.1.SG eaten-M.SG/*F.SG the apple.F.SG
“I have eaten the apple.” (D’Alessandro & Roberts 2008)
- b. **Due ladri** sono entrat-**i**/*o dalla finestra
two robbers are entered-M.PL/*M.SG from-the window
“Two robbers entered from the window.” (Belletti 2006: ex.34c)
- c. **Alcuni sindaci** sono stati arrestat-**i**/*o
some.M.PL mayors.M.PL are.PL been.M.PL arrested.M.PL/*SG
“Some mayors were arrested.”

He argues that this pattern has a natural explanation if we formally dissociate the Merge and Agree operations that typically constitute an EPP property. A head with an EPP property might therefore be described as having two separate features: a probe and a Merge feature. Important to note is that the Merge feature may be satisfied by either internal or external Merge. This is the featural makeup that Longenbaugh proposes for a transitive *v* head.

(6) Feature makeup of *v*:

- Agree: [$u\varphi$], for triggering PPA
- Merge: [$\cdot D \cdot$], for introducing the external argument

On this view, the argument that satisfies the φ -probe need not be the argument that satisfies *v*’s Merge feature. However, they often *are* the same due to an economy condition, which he calls *Feature Maximality* (based on Chomsky (1995)’s *free rider* constraint). He additionally assumes the following properties of φ -probes.

- (7) **Feature Maximality:** Given a head H with features [F_1]...[F_n], if XP discharges [F_i], XP must also discharge each [F_j] that it is capable of (based on Rezac 2013; van Urk & Richards 2015, among others)
- (8) **Case accessibility:** In the relevant Romance languages with this pattern, only DP’s with unmarked case are accessible to φ -Agree (based on Bobaljik 2008; Preminger 2014)

(9) Agree is always downward

Because Romance languages are nominative-accusative, and their φ -probes are proposed to discriminate against accusative case, whether the internal argument is available for Agree depends on when and whether case is assigned. Longenbaugh assumes that accusative case is a dependent case, whose assignment depends on a stage in the derivation where one argument c-commands another in a particular domain. He additionally proposes that the domain for accusative case assignment is vP and that dependent case assignment happens early, upon introduction of a second argument in Spec vP (i.e. upon completion of the vP domain). External Merge of the subject is therefore immediately followed by dependent case assignment, which evaluates both the recently merged subject and any arguments in its c-command domain.

On this view, if external Merge precedes Agree, dependent case assignment renders the internal argument inaccessible to subsequent Agree. Following Preminger (2009, 2014), Longenbaugh assumes that Agree can fail without crashing the derivation². If Agree precedes external Merge, however, PPA should occur. We will now see that feature maximality enforces the former derivation for a transitive clause. If v has a φ -probe and a requirement for a DP specifier, v can choose amongst three potential operations that would each satisfy one or more of its features after merging a VP complement:

1. Agree with the object
2. Internally merge the object
3. Externally merge the subject

If v chooses the first option to agree with the internal argument, feature maximality requires it to also perform option two and internally merge the argument that it just agreed with. Therefore, agreement with the internal argument saturates all of the features on v . Assuming that all Merge is feature driven, this bleeds the possibility of merging an external argument. This derivation must therefore be unaccusative or passive since a normal external argument cannot be introduced in the clause.

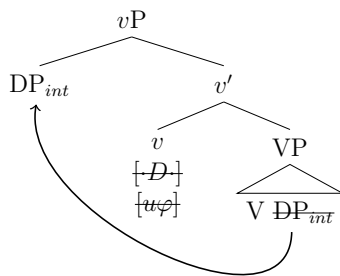

Figure 2: Agree/movement of the internal argument blocks Merge of the external argument by satisfying all the features on v .

²In general, he assumes that all conceivable features on a head are always present, but are allowed to fail as long as the resulting structure converges. For example, all of the \bar{A} -features that trigger successive cyclic movement through Spec vP are presumed to be present on v in these cases as well, but since there are no wh-phrases in the transitive derivation under consideration, they can be ignored here.

If v instead chooses option three first, namely to externally merge the subject before agreeing with the object, the external argument can now saturate the D feature and the clause can be transitive. However, if merging the subject triggers dependent case assignment on the object, this step now bleeds φ -agreement with the object. Assuming Agree only happens in v 's scope with nominative marked arguments, v 's φ -probe now fails, and the result is the lack of PPA in transitives.

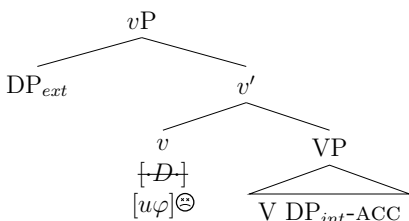

Figure 3: Merging the external argument blocks Agree by triggering accusative case assignment on the internal argument.

This system therefore makes the right predictions for simple transitive/passive/unaccusative clauses. The idea is that merging one argument bleeds the possibility of merging the other, and which one you do first has consequences for Agree. This raises the question of what would happen if v had to project multiple specifiers. For example, if the object is a clitic or a wh-phrase, it presumably needs to move through the edge of vP at some point in the derivation without blocking the external argument. Apparently multiple specifiers at v have varying consequences for PPA across languages.

In French, clitic and wh-objects co-occur with optional PPA in French. In Italian, clitic objects might or might not trigger PPA depending on the features of the clitic (obligatory PPA with 3rd person, optional with 1st/2nd), while wh-objects never co-occur with PPA.

(10) Clitics/wh-objects trigger optional PPA in French

- a. Jean ne **les** a jamais fait(**es**)
 Jean NEG them.CL have.3SG never done-F.PL

“John has never done them.”

- b. **Les sottises** [que Jean n’a jamais fait(**es**)]...
 the stupid-things.F.PL that Jean NEG.have.3SG never done-F.PL

“The stupid things that John has never done...” (Longenbaugh’s adaptation from Belletti 2006)

(11) Clitics trigger optional/obligatory PPA in Italian, no PPA with wh-phrases

- a. **Ci/vi** ha vist-**e/i/o**
 CL.1.PL/CL.2.PL has.3.SG seen-F.PL/M.PL/M.SG

“He has seen us/you (pl).”

- b. **Quanti libri** hai lett-**o/*i?**
 how.many.M.PL books.M.PL have.3.SG read-M.SG/*M.PL

“How many books have you read?” (Belletti 2006)

To explain this variation, Longenbaugh assumes firstly that in order to project multiple specifiers, v must have some more Merge features. We can represent movement of a clitic to the edge of vP with a Merge cl feature and movement of a wh -object as a Merge wh feature. We will ignore any potential probes that are associated with these Merge features as they have no exponent and can always fail.

With the addition of more Merge features, it is now possible that merging one argument will not bleed another Merge step. Focusing on wh -movement, as long as the present arguments can satisfy different Merge features on v , the order of operations is argued to be less crucial, thus leading to derivational optionality. Longenbaugh proposes that each derivational option has a different result for PPA. Either the subject merges first, blocking PPA by assigning the object accusative case, and then the object moves, or v can agree with and move the object first, thus licensing PPA, and then introduce the subject. He argues that this derivational optionality accounts for optional PPA in French, and that a separate wh -anti-agreement rule (Baier, 2018) applies in Standard Italian, which masks the optionality by uniformly blocking PPA in transitive wh -questions.

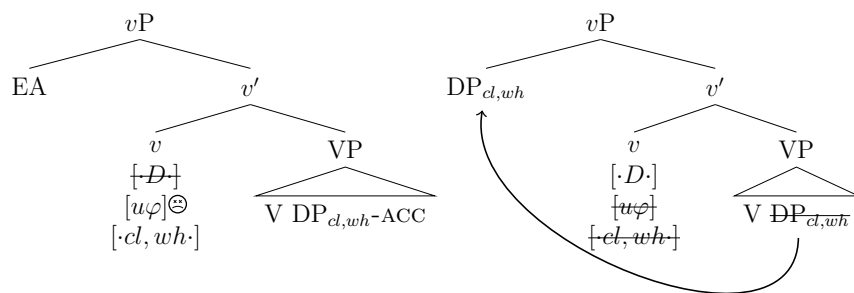
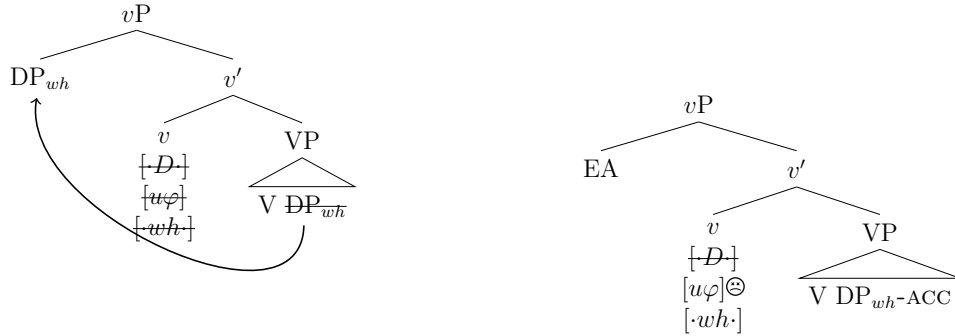

Figure 4: French: there is derivational optionality wrt which argument merges first, leading to optionality in PPA

The proposed presence of derivational optionality is dependent on a crucial assumption, namely the stipulation that only one Merge feature can be satisfied at a time. I argue that this constraint is untenable upon further scrutiny, and propose that the theory is ultimately more successful without it. Let us first consider the theory without it.

Allowing feature maximality to multiply satisfy Merge features predicts wh -objects (and possibly clitics) to behave no differently than regular objects. This is because wh -objects have a *superset* of the features that the subject has. If allowed to satisfy multiple Merge features at a time, internal Merge *would* bleed external Merge. There is no derivational optionality for an object wh -question because only one derivation allows the clause to be transitive, namely the one in which the subject merges first. This would predict no PPA for object wh -questions (I am leaving aside clitic objects in the absence of a theory of clitic features/movement compared to D features/DP movement).



(a) If feature maximality led to saturation of Merge features at a time, internal Merge of a wh-object would bleed external Merge.
 (b) Predicted first step of derivation if multiple Merge features could be satisfied at once. The external argument would have to merge first, bleeding PPA.

Note that while this amended proposal fails to account for optionality in French, it correctly rules out PPA in Standard Italian object wh-questions. I will argue that we should adopt the most general version of feature maximality, which explains Standard Italian but not French, for two reasons. First, it is not clear that PPA in French is truly optional in these cases. Déprez (1998) has argued that the presence or absence of PPA in object extraction correlates with semantic effects. If Longenbaugh’s proposed derivations for object wh-movement are correct, the object always moves to the same position for the same reason regardless of whether PPA occurs. It is therefore unexpected that the interpretation of the object should have anything to do with the morphology on the verb. One way of analyzing French in light of Deprez’s observation is to conclude that PPA is also generally ruled out in object wh-questions (as is the case for Italian), but may be independently licensed by another probe with semantic consequences.

An additional reason to reject Longenbaugh’s constraint on feature satisfaction is that it makes false predictions for subject wh-questions. If only one Merge feature can be satisfied at a time, subject wh-questions are predicted to trigger object movement and license optional PPA, contrary to fact.

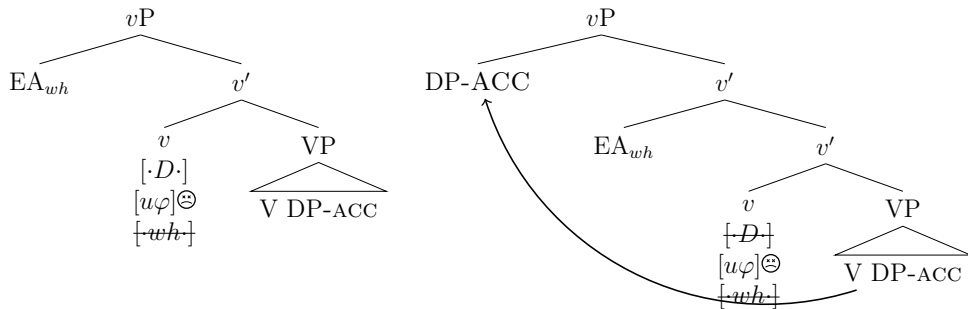

Figure 6: If only one Merge feature could be checked off at a time, a subject wh-word that merges first could check off a Merge wh feature *without checking off a Merge D* feature, thus licensing subsequent movement of the object → object movement but no corresponding PPA.

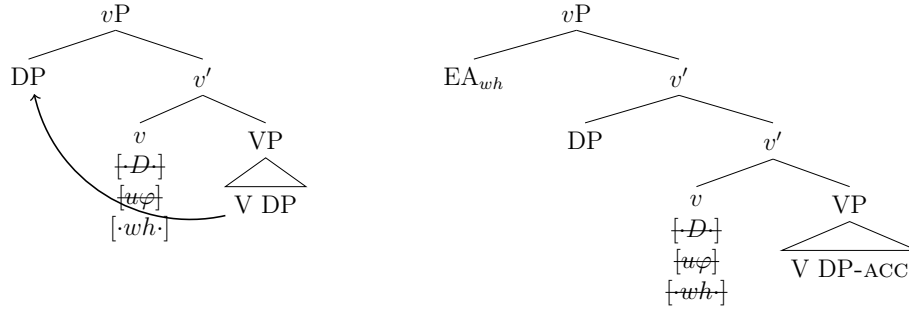

Figure 7: Similarly, a subject wh-word could also merge second after agreement with and movement of the internal argument, because a merge wh feature is still unsaturated on $v \rightarrow$ object movement and PPA.

Longenbaugh proposes in earlier work that these options are ruled out by a general constraint on what Merge features can ‘introduce’ arguments. I take his meaning to be that only A-features can license external Merge, while \bar{A} -features can only license internal Merge.

I will propose a different approach. There are independent reasons to suspect that multiple Merge features indeed *can* be satisfied by a single merge operation (and in some cases it appears they must be). Taking these examples at face value would advocate treating Italian as the default case of PPA, and obviate the need to invoke any constraints on what sorts of Merge features can license external Merge.

One such instance where we see multiple Merge features satisfied by a single element is wh-movement in V2 languages. Assuming that V2 languages like German and Dinka require some XP to move to Spec CP, we might posit that German C always bears a *Merge X* feature.

According to Longenbaugh’s proposal, wh-movement to Spec CP must also indicate the presence of a *Merge wh* feature. However, these two Merge features on C never trigger separate merge operations. Dinka and German wh-questions only ever involve movement of one argument to Spec CP, namely the wh-phrase (in wh-movement contexts, Dinka also allows wh-in situ, in which case another phrase may move to satisfy V2).

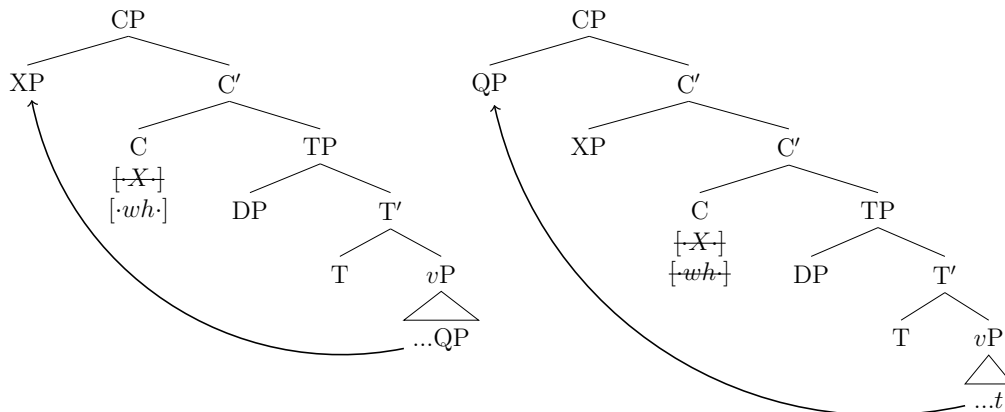

Figure 8: If only one Merge feature could be satisfied at a time, two merge operations are predicted to be possible for wh-movement in V2 languages, contrary to fact.

If movement could only satisfy one of the features at a time, we would expect a V3 pattern

to be possible. Movement of a wh-phrase would satisfy the wh-feature, and movement of some other XP would satisfy the X-feature. This is not observed.

- (12) *German*
- a. Welchen Film hat die Pia geschaut?
which.ACC film has the Pia watched
'Which film did Pia watch?'
 - b. *Welchen Film die Pia hat geschaut?
 - c. *Die Pia welchen Film hat geschaut?

- (13) *Dinka* (van Urk & Richards 2013)
- a. Yeŋó cí ńór kuèen?
what PRF.NS Ngor.GEN read
'What did Ngor read?'

A straightforward explanation of the V2 pattern for wh-questions is an economy condition of the form: a head should satisfy its requirements with as few operations as possible. As long as the features that satisfy V2 are a subset of the features of a wh-phrase, moving a wh-phrase that can satisfy both Merge features is preferable to moving multiple phrases.

If we wanted to maintain Longenbaugh's view, we could alternatively imagine that this pattern is not explained by a merge operation targeting two Merge features. We could instead imagine that there is some surface requirement on V2 languages not to have multiple specifiers (along the lines of Pesetsky 2000), and some other principles of interpretation that require the wh-phrase to be the thing that moves.

However, we also see the same effect for wh-traces in embedded clauses. Long distance wh-movement acts as though traces of wh-phrases in embedded Spec CP's behave like overt wh-phrases in matrix Spec CP; they likewise do not co-occur with other XP's in that position, despite the fact that embedded V2 is possible in both languages³. Since the wh-phrase is not usually pronounced in the lower position, a surface constraint couldn't account for this pattern. It appears rather that the syntax rules out multiple movements to that position.

- (14) *German* (Branigan 1996: 58-66)
- a. Wie hat sie gesagt [_{CP}___ haben die Kinder Geschichte gelernt]?
how has she said have the children history learned
'How did she say the children learned history?'
 - b. *Wie hat sie gesagt [_{CP}die Kinder haben Geschichte gelernt]?
how has she said the children have history learned
intended: 'How did she say the children learned history?' (low adjunction reading)

- (15) *Dinka* (van Urk & Richards 2015: 16)

³For both languages, the conditions on embedded V2 are more complicated than I am presenting here. For example, the effect of embedded complementizers on V2 is not discussed here. However, what is crucial for my argument is only that embedded V2 is possible in some contexts, but long-distance wh-movement *never* co-occurs with embedded V2. In other words, my examples have in common the fact that these embedded clauses would otherwise be able to have V2 order, except for the fact that a wh-phrase has moved through its edge. For more discussion of embedded V2 in general, see Vikner 1995, van Urk 2015, etc.

- a. Yeqà cúkkú luéel, [_{CP} ____ cí kitàp yòoc]?
 who PRF.1PL say PRF.NS book buy.TR
 ‘Who did we say bought a book?’
- b. *Yeqà cúkkú luéel, [_{CP} kitàp cí yòoc]?
 who PRF.1PL say book PRF.NS buy.TR
 intended: ‘Who did we say bought a book?’

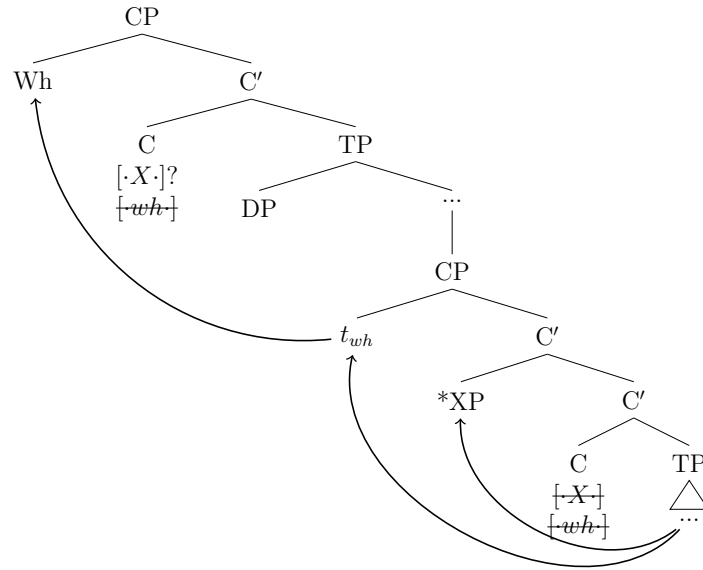

Figure 9: Long distance wh-movement bleeds embedded V2.

Dinka additionally demonstrates this pattern in the *vP* domain (*vP* V2), suggesting that this is not a unique property of CP’s. We already had independent reasons to suspect that *vP*’s must be able to host multiple specifiers. For instance, *v* must be able to both host an external argument and move an object wh-phrase through its edge. Dinka in principle has the option to host three specifiers: an external argument, an internally merged DP, and a wh-phrase. However, wh-movement of an argument seems to bleed internal Merge of a second DP.

(16) Dinka *vP*’s are V2 (van Urk & Richards 2015: 12-13)

- a. yèn cí Ayén yién kitàp.
 I PRF Ayen give book
 ‘I gave Ayen a book.’
- b. yèn cí kitàp yién Ayén.
 I PRF book give Ayen
 ‘I gave Ayen a book.’
- c. *yèn cí ____ yién Ayén kitàp/kitàp Ayén .
 I PRF give Ayen book/book Ayen
 intended: ‘I gave Ayen a book.’

Unlike for CP V2, this *v*P position cannot be filled by an adjunct, suggesting that it has a merge D feature rather than a merge X feature.

(17) Adjuncts cannot satisfy *v*P V2 (van Urk & Richards 2015: 13)

- a. Wò cí ____ kèt dòm-íc.
 we PRF sing garden-in
 ‘We sang in the garden.’
- b. *Wò cí dòm-íc kèt.
 we PRF garden-in sing
 intended: ‘We sang in the garden.’

If either internal argument is wh-moved, however, this position must be unoccupied, suggesting that wh-movement through Spec *v*P bleeds satisfaction of this merge D feature by another phrase.

(18) Wh-traces saturate *v*P V2 (van Urk & Richards 2015: 15)

- a. Yeɲà cí m̀òc ____ yiɲn kitàp?
 who PRF.NS man give book
 ‘Who did the man give the book to?’
- b. *Yeɲà cí m̀òc kitàp yiɲn?
 who PRF.NS man book give
 intended: ‘Who did the man give the book to?’

This is unexpected if wh-movement cannot saturate both the wh and D features in single operation⁴. To summarize, I propose we replace Longenbaugh’s stipulation that rules out multiple satisfaction of Merge features and adopt a stronger economy condition inspired by those proposed in Pesetsky & Torrego (2001); Richards (2012); van Urk & Richards (2015).

(19) Derivational economy: At every step in a derivation, if two operations A and B are possible, and A checks off more features than B, the grammar prefers A.

There is an immediate problem with this condition, however, which is that transitive declarative clauses seem to violate it. Derivational economy asymmetrically prefers internal Merge to external Merge because internal arguments are also accessible for *Agree* by *v* as well as Merge, unlike external arguments, which can only satisfy a Merge feature. Despite the fact that the external argument satisfies a subset of the features that the internal argument could, the theory must allow external Merge to apply first in normal transitive clauses or else external arguments would never be licensed.

I propose that derivational economy must therefore be sensitive to pressure from the need to assign theta roles. If an external theta role is not assigned before all of *v*’s features have

⁴We could in principle test this behavior in languages whose *v* heads were more like Romance *v* heads in only ever having one non-wh DP specifier. We would need to find a language with ditransitive unaccusatives. If Longenbaugh was right, we would expect wh-movement of one of the arguments to cause the second internal argument to also move. If I am right, only one argument should move, namely the wh-phrase.

been saturated, the clause can never be transitive, which demands the existence of derivations in which derivational economy is violated⁵.

- (20) Derivational economy (revised): At every step in a derivation, if two operations A and B are possible, and A checks off more features than B, the grammar prefers A, *unless doing A bleeds theta role assignment*.

This amendment explains the lack of V3 order in V2 wh-questions. Since Spec CP is not a theta position, the derivation requires the earliest operation to also be the most productive in the sense of checking off the most features. Therefore, the first operation C should trigger is wh-movement, since it satisfies all of its Merge features. This bleeds further operations, resulting in only one specifier of CP.

It likewise explains why merging a wh-subject in Romance does not suddenly license object movement. External Merge of a wh-subject should satisfy both the wh and D features on *v*, forcing a non-clitic object to remain in situ.

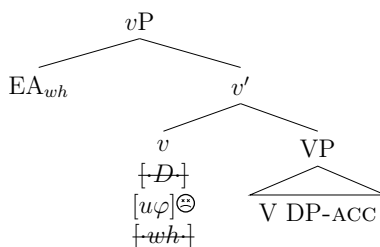

Figure 10: External Merge of a wh-subject no longer predicts object movement in Romance.

While I believe these amendments to the theory are necessary to explain general properties of movement, they do not fix one of the more surprising predictions about PPA, however. We just saw a derivation of subject wh-questions in which external Merge was the first operation, but in reality derivational economy does not tell us which operation should go first. External Merge satisfies two features on *v*, but internal Merge *also* would have satisfied two features on *v* (D and φ). Crucially, internal Merge *does not bleed theta role assignment* because there is a leftover feature on *v* that can be satisfied by externally merging a subject, namely the wh-feature. Therefore, we should expect optionality between the derivation in Figure 10 and Figure 11, the latter of which licenses PPA.

⁵Some might have qualms about the global nature of this constraint. Two features of the proposal should partially assuage these worries, though the topic certainly merits further discussion. 1) The look-ahead problem introduced by global constraints is of very short duration in this case, because choosing not to violate derivational economy immediately leads to a crash. 2) It is possible to reframe this constraint as a local condition if we are willing to make explicit reference to unmerged elements in the numeration. I leave this as a topic for future research.

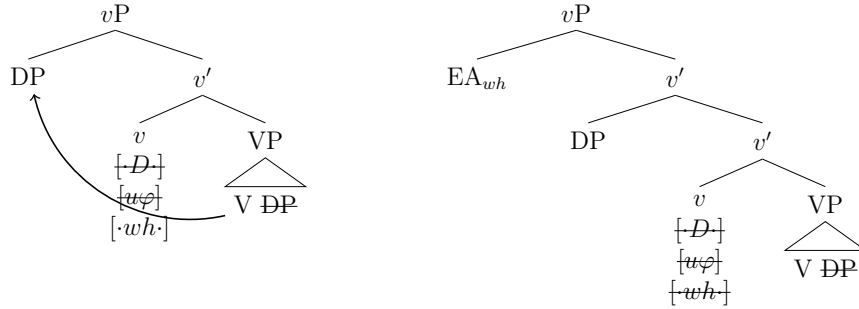

Figure 11: A subject wh-word could also merge second after agreement with and movement of the internal argument, because a Merge wh feature is still unsaturated on $v \rightarrow$ object movement and PPA.

This optionality is not observed. No Romance language that I know of allows PPA in passives, unaccusatives, and subject-wh-questions to the exclusion of transitives and object wh-questions. That said, the prediction that subject-wh-questions should look derivationally intransitive is notoriously true of certain other languages.

Languages with the so-called Ergative Extraction Constraint are identified by special morphology that is associated with their subject-wh-questions. Most commonly, the corresponding morphology mimicks that of an intransitive clause (Aldridge, 2004; Coon et al., 2014). I will argue that the existence of such languages is further evidence in support of the amendments to the theory that I am proposing, and that this theory is best suited to explain these phenomena compared to other approaches. I first summarize the state of the current proposal with my amendments to Longenbaugh’s theory, followed by an analysis of Mayan EEC effects.

Something that Longenbaugh is not explicit about is the order of multiple specifiers. I will follow Richards (1997) and propose that multiple specifiers must tuck in. Richards proposes that tucking in is the result of a constraint on movement, namely *Shortest Move*. An incidental by-product of Shortest Move is that internal Merge results in a specifier that is maximally local to the Merge feature that it satisfies. It could be that the system cares about this local environment more so than the distance between the base and landing position of the moving element. If so, we would expect external Merge to also have to ‘tuck-in’ to end up maximally local to the Merge feature that it satisfies. In the interest of pursuing this general program of making internal and external Merge formally identical, I therefore assume that tucking in is a general property of merge, not just internal Merge.

Economy conditions:

- Derivational economy (revised): At every step in a derivation, if two operations A and B are possible, and A checks off more features than B, the grammar prefers A, *unless doing A bleeds theta role assignment*.

Conditions on Merge:

- All merge tucks in (Richards, 1997)

Conditions on case and agree:

- Dependent case assignment: Case on a DP or its dependent is assigned upon the completion of a *vP*
- Case accessibility: φ -probes may be relativized to look only at DP's with unmarked case, or both unmarked and dependent cases (Bobaljik, 2008; Preminger, 2014)
- Agree is always downward

3 Mayan Agent Focus

A well-studied ergative extraction phenomenon is found in so-called high absolutive Mayan languages. While normal agreement alignment in Mayan transitive clauses cross-references both the subject (glossed A) and the object (glossed B), extraction of a transitive subject in some Mayan languages results in a loss of agreement with the subject. Instead, a different morpheme appears, called the *Agent Focus* morpheme.

- (21) Transitive clauses include both subject and object agreement
 a. Max-ach y-il-a'
 ASP-B2S A3S-see-TV
 'She saw you.' (Coon et al. 2014: 10)
- (22) Subject \bar{A} -extraction bleeds subject agreement, requires a special morpheme glossed AF
 a. Maktxel max-ach il-**on**-i?
 who PFV-B2S see-AF-ITV
 "Who saw you?" (Q'anjob'al; Coon et al. 2014: 213)
- b. Are ri sis x-ti'-**ow** ri kumatz
 FOC DET coati PFV-bite-AF DET snake
 "The coati_F bit the snake." (K'iche'; Can Pixabaj 2004: 56)
- (23) *Without AF
 a. *Maktxel max y-il ix ix?
 who PFV A3S-see CLF woman
 intended: "Who saw the woman?" (Q'anjob'al; Coon et al. 2014: 193)
- b. *Are ri ixoq x-u-b'aq ri ch'ajo'n
 FOC DET woman PFV-A3S-scrub DET clothes
 intended: "The woman_F scrubbed the clothes." (K'iche'; Can Pixabaj 2004: 58)

Extraction of an object, on the other hand, results in the normal transitive agreement alignment. Agreement with both arguments is obligatory and Agent Focus is ruled out. Important to note is that B agreement is generally null for third person singular arguments.

- (24) Maktxel max y-il naq winaq
 who PFV A3S-see CLF man
 "Who did the man see?" (Q'anjob'al; Coon et al. 2014: 192)

This pattern is considered to be an ergative extraction phenomenon because Mayan agreement generally looks ergative-absolutive, even though there is no overt case morphology. There are two slots for φ -agreement in the clause. One is called Set A in the Mayan literature, and cross-references transitive subjects. The other is called Set B and cross-references transitive objects and intransitive subjects. Assuming that abstract case can be covert, we can describe the pattern as though Set B targets absolutive arguments while Set A targets ergative arguments. The morphological template on the verb is schematized in example (25).

- (25) TAM - (Set B) - Set A - [Root - (Voice) - (Status Suffix)] - (Set B)
 Set B morphemes may appear on different sides of the verb depending on the language/number of TAM particles

Important to the discussion of extraction asymmetries is the fact that the source of Set B agreement is not homogeneous across Mayan languages. In some languages, Set B occurs in both finite and non-finite clauses, while in others it only occurs in finite clauses. Languages whose Set B agreement is *insensitive* to finiteness are called *low absolutive*. Set B agreement in low absolutive languages is presumed to expone a φ -probe on *v*, which is presumably present in both finite and non-finite clauses. Languages whose Set B agreement only occurs in finite clauses are called *high-absolutive*. Set B agreement in high absolutive languages is supposed to occur on T, which is presumably only present in finite clauses.

- (26) Set B is sensitive to finiteness in High- but not Low absolutive languages

- a. *Ch'ol* - *Low absolutive* (Vázquez Álvarez 2011: 99)

K-om [j-kãñ-ety]
 A1-want A1-knowB2

‘I want to speak to you.’

- b. *K'iche'* - *High absolutive* (Can Pixabaj 2015: 116)

X-u-chap [nu-kuna-x-iik]
 PFV-A3S-begin A1S-cure-PASS-ITV

‘She began to cure me.’

- (27) Summary of the distribution of φ -probes from Coon et al. (2014)

- a. **High-absolutive:** Set B agreement is controlled by finite T
 b. **Low-absolutive:** Set B agreement is controlled by *v* in transitives and finite T in intransitives

Tada (1993: 106) observes a correlation between the location of Set B agreement in a language and whether that language has the extraction asymmetries like in (22) and (24). Only the high absolutive Mayan languages exhibit extraction asymmetries, a correlation which has been dubbed *Tada's generalization*. The remainder of this section will be devoted to understanding subject extraction in high absolutive languages. Low absolutive languages will be revisited in Section 5.

While the source of Set B differs across languages, there is no reason to suspect that the same is true for Set A agreement. Set A always appears in both finite and non-finite contexts and has a uniform position in the verb stem. It seems therefore that Set A must be expone on a head lower than finite T in both high and low absolutive Mayan languages. Coon et al.

(2014) propose that Set A is the exponent of v after a process of feature sharing between v and its specifier. This view requires v to be sensitive to whether its specifier was internally vs. externally merged, however, because Set A only occurs with transitive subjects. If v *always* shared the features of its specifier, we would expect intransitive subjects to yield Set A agreement as well.

In the absence of a general theory of spec-head feature sharing, and in the interest of maintaining the insights of Longenbaugh’s system, I will propose that Set A, like Set B, is a normal downward probing φ -probe on a head between v and finite T. A candidate for this Set A probe is Voice. Ranero (2019) has shown, with evidence from active-passive mismatches in ellipsis, that Mayan languages have a structure like that proposed by Merchant (2013).

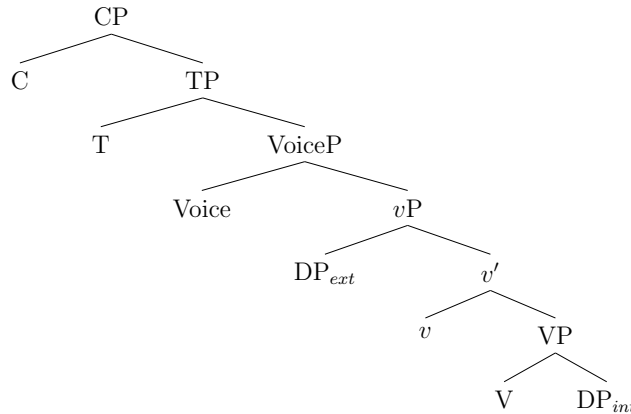

Figure 12: Proposed clause structure from Merchant (2013).

Assuming that Voice is the locus of the active-passive distinction, for VP ellipsis to allow active-passive mismatches, it must target a constituent below Voice (or else identity with the antecedent VP would not be met). Merchant has shown for English that the elided constituent may contain the transitive subject, thus advocating for a view in which Voice c-commands the base position of the external argument in addition to the rest of the verb phrase. Ranero has corroborated similar facts in Mayan, so I assume his clause structure is appropriate for Mayan as well. A Set A probe on Voice could therefore probe downwards and agree with a transitive subject in Spec v P.

An advantage to this approach is that Set A agreement is only predicted to occur in clauses that project a VoiceP. By hypothesis, only clauses that can undergo the passive alternation have a VoiceP. Since the passive alternation requires promotion of an internal argument and demotion of a transitive subject, transitive clauses should project Voice, but unergative/unaccusative clauses should not. This proposal therefore straightforwardly predicts the presence of Set A in finite and non-finite transitive clauses, but its absence in intransitive clauses.

With these assumptions, we might wonder what other conditions we must place on these probes to ensure that Set A always cross-references the ergative subject and Set B always cross-references the absolutive object. One approach is to take the case sensitivity of these probes at face value. Since Set B only cross-references absolutive arguments, it is reasonable to suppose that it is case discriminating. Set A, on the other hand, appears not to mind if its closest goal is marked ergative. I therefore propose the following descriptions of these probes.

- T’s φ -probe agrees with the closest **absolutive** argument

- Voice’s φ -probe agrees with the closest argument

Assuming nothing else happens in the course of the derivation, these assumptions predict that Set A agreement will cross-reference the subject because it is the closest argument to it, while Set B will skip over the subject and agree with the object, which is the closest *absolute* argument to it.

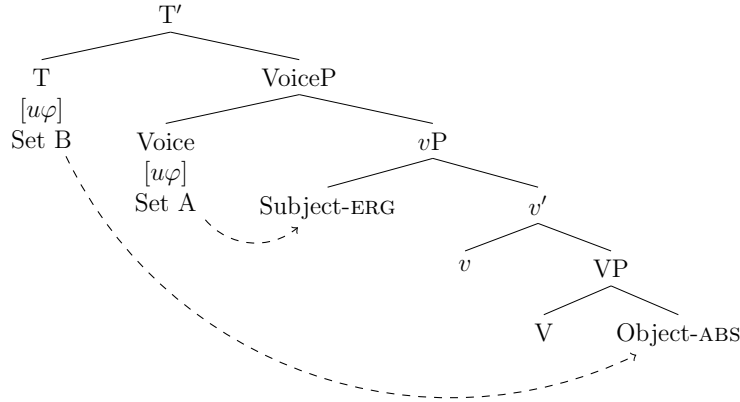

Figure 13: If T is case-discriminating, it will skip the ergative subject and agree with the object.

The tree in Figure 13 is a departure from common assumptions about the position of the object in high absolutive Mayan languages, however. It is argued in Coon et al. (2014) that an in situ object is inaccessible to Agree by a probe outside of v since the vP is presumably a phase. The object must therefore move to become visible to the high absolutive probe. By Longenbaugh’s logic, if the object moves it must do so after the subject has been introduced or else it would bleed the possibility of inserting a subject. Taking this for granted, I assume that if the object moves, it must tuck-in under the subject according to Richards (1997)’s *Shortest Move*.

It is worth noting that not every theory of phase spell-out requires the object to move for it to be visible to Agree. If we assumed the weak PIC (Chomsky, 2001), the complement of v wouldn’t be expected to spell out until after C is merged. This would make the object visible to T at the time that T is merged, so object movement would not be necessary. As we will see in section 3.1, we may independently need to assume the weak PIC to account for the behavior of NP and reflexive arguments.

A broader discussion on the relevance of object movement to theories of the EEC will be undertaken in Section 5. For now, I will assume with Coon et al. (2014) that the object is normally high in these languages, which will prove useful in illustrating the proposal. We will see, however, that the placement of the object may not be crucial to describe the distribution of Agent Focus, as will be discussed in Section 5.

At this point, we have enough information to posit a feature structure for v in high absolutive Mayan languages. Minimally, transitive v must have a D feature to merge the subject, a φ -probe to find the internal argument, and another feature to trigger internal Merge of the object. There is a general question of how to enforce object movement to Spec vP . If vP simply had two merge D features, given that multiple Merge features can be satisfied at a time, there is

nothing to prevent one DP from satisfying them both. As Longenbaugh proposed, cases of object movement in Romance correlated with the presence of an additional feature, e.g. clitic features.

His suggestion may be applicable to Mayan if we wanted to treat object movement as a clitic doubling structure that feeds higher agreement. Many researchers have proposed that Set B morphemes arise through clitic doubling of full DP arguments (see: Grinevald & Peake 2012 and Mateo-Toledo 2008 on Q’anjob’al; Woolford 2000 on Popti’; Coon 2013 on Chol; and Preminger 2011a on Kaqchikel). This approach accounts for the clitic-like behavior of Set B, which can sometimes appear as an independent pronoun. While clitic doubling is typically proposed to occur on finite T, it is conceivable that the clitic is produced lower, which feeds normal agreement by the higher probe where it ultimately gets pronounced.

Alternatively, following Müller (2010), we could imagine that some Merge features are simply relativized to only be satisfied by internal Merge. On this view, internal arguments could satisfy any kind of merge D feature, but external arguments could only satisfy those that are not relativized to internal Merge. This is a somewhat unsavory stipulation if we want to maintain unity between internal and external Merge, but may be necessary if we think that high absolutive languages don’t have clitic doubling at v . In order to remain agnostic between these two possibilities, I will use the description *Merge Object* as a placeholder.

- (28) Features on v : $[\cdot D\cdot]$, $[\cdot O\cdot]$ (for moving the object), $[u\varphi]$, and then \bar{A} -features ($[\cdot wh\cdot]$, $[wh]$, etc.)

We will now formally see why this set of features predicts transitive agreement alignment for a regular transitive clause. If movement of the object can satisfy both the D and O features on v , then internal Merge can bleed external Merge much as we saw for Romance. Therefore, the external argument must merge first if this clause is ever to be transitive. When the external argument is merged, it is evaluated for case. Since it c-commands a case competitor, it is assigned ergative.

Finally, the internal argument is internally merged, which tucks in under the subject and satisfies the rest of the non- \bar{A} features on v . This results in two specifiers of vP in the order SO.

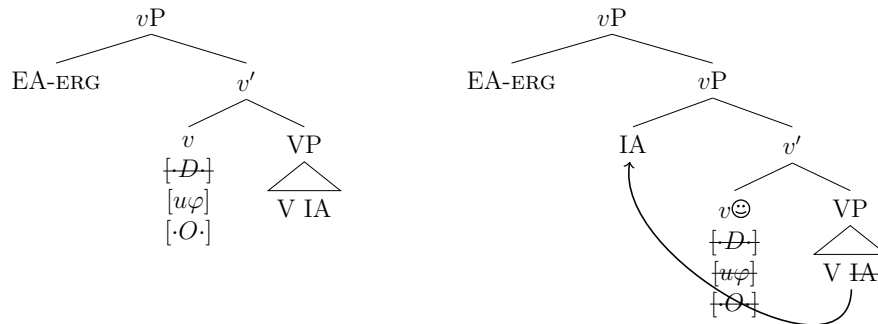

Figure 14: If the internal argument satisfies all of v 's features, it must be moved second or else it would block insertion of the external argument.

This order of operations feeds transitive agreement alignment. Since the outer specifier is marked ergative, it is accessible to Agree by Voice but not by T. Thus Set A agreement

cross-references the higher argument, namely the subject, and Set B cross-references the lower argument, namely the object.

Notice that the same derivation is predicted if the object has wh-features. Increasing the number of features on the object merely ensures that internal Merge of the object should saturate not just the D and O features, but also the wh feature, therefore blocking potential insertion of a subject just as before. So again, external Merge must apply first, followed by dependent case assignment and internal Merge, predicting that object wh-questions should have the same agreement alignment as a regular transitive clause⁶.

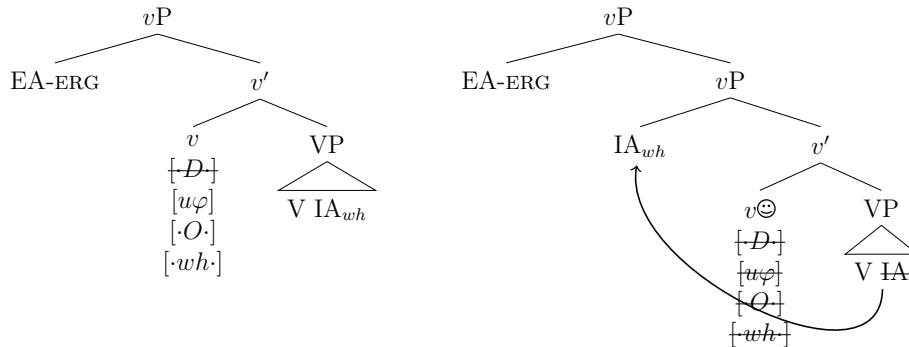

Figure 15: If the internal argument satisfies all of v 's features, it must be moved second or else it would block insertion of the external argument.

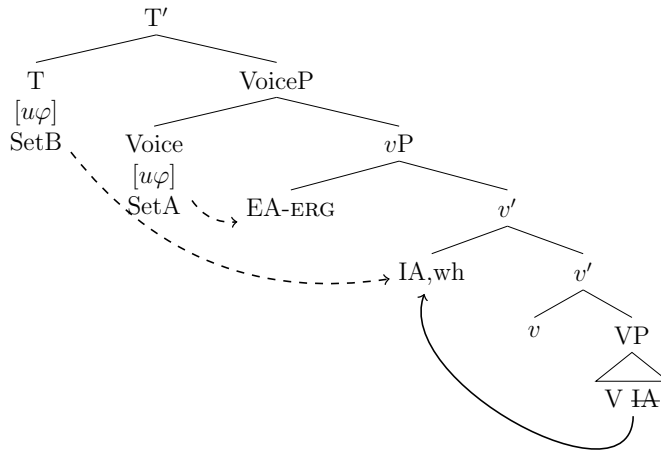

Figure 16: Voice agrees with closest DP, namely the ergative marked outer specifier of vP . T agrees with the closest absolutive marked DP, which is the inner specifier of vP .

⁶In general, I will be ignoring the distribution of wh-probes, since they will not affect the derivations here. Classical theories of EPP properties in which internal Merge is crucially mediated by Agree stipulate the presence of these probes if we want to have internal Merge at all. However, given that Merge features are also responsible for *external* merge, they must be able to search for elements in the numeration without the help of agree. Provided that this search function can also find already-merged elements, there may not be a need to posit a wh-probe (i.e. Agree feature) at all (unless a language were to have overt special wh-agreement). This is a topic for future research.

This system and the proposed distribution of φ -probes therefore correctly predicts that transitive clauses and object wh-questions should have the same agreement alignment. The reason for this is that both derivations place the ergative-marked subject as the outer specifier of vP , which is accessible to the φ -probe on Voice but not to the φ -probe on T.

Imagine, however, that the outer specifier is not an ergative subject, but an absolutive argument (regardless of what the argument is). Assuming that the clause still contains all of the functional projections of a transitive clause, *both* Voice and T should agree with the outer argument and bleed agreement with the other one. The system predicts such a derivation to be possible if the transitive object is marked oblique for some reason or if the subject is allowed to merge late after the object moves. While we never observe a clause in which both Set A and Set B cross-reference the same argument overtly, we *do* observe that special morphology arises in exactly the places where we would expect a derivation to result in an absolutive outer specifier: subject wh-movement and anti-passive.

Starting with subject wh-questions, we note that unlike regular DP subjects, subject wh-phrases may adjoin to v whether or not v 's D feature has been saturated. This is because they may independently satisfy v 's wh feature instead. Because of this, movement of the object no longer bleeds insertion of a subject. Derivational economy in fact requires the internal argument to move first because it can satisfy the most features on v , without bleeding theta role assignment on the transitive subject (when it eventually merges).

To summarize, derivational economy requires the object to move first because it satisfies the most features, and doing so will not bleed theta role assignment because the subject has other features that allow it to become v 's specifier later. The object does not c-command a case competitor in its base or landing position so it is unmarked for case. The wh-marked external argument may then externally merge, saturating v 's wh feature, and tucking in under the object (because all merge tucks in). The external argument also never c-commands a case competitor⁷, so it is also left unmarked for case.

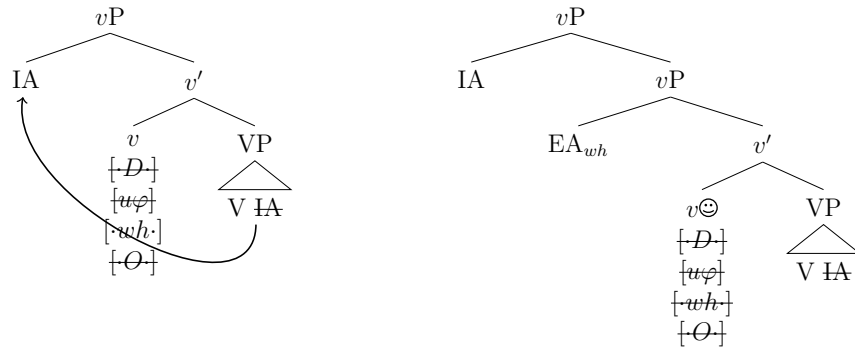

Figure 17: Subject wh-questions: 1. move IA 2. assign IA absolutive case 3. merge EA 4. assign EA absolutive case (because it doesn't c-command a case competitor in its vP)

The crucial point is that the order of operations is reversed just in case the subject has additional features (such as wh-features) that allow it to merge late. In these cases, the outer specifier is now the object, the inner specifier is the subject, and both are absolutive because neither c-commands a case competitor at the time that it is evaluated for dependent case

⁷I assume that traces are not case competitors.

assignment. Because the outer specifier of v is unmarked for case, both T and Voice agree with it, which I propose gets pronounced as one overt exponent of those features plus the AF morpheme⁸.

- (5) *Anti-redundancy*: two adjacent φ -probes that cross-reference the same argument must delete the lower probe. Deleted feature bundles get spelled out as an elsewhere form.

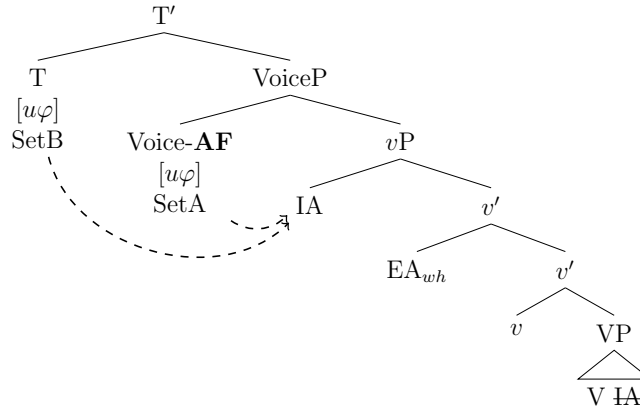

Figure 18: Voice agrees with closest DP, namely the absolutive marked outer specifier of v P. T agrees with the closest absolutive marked DP, which is the same outer specifier of v P. Set A agreement therefore cross-references the same DP as Set B agreement resulting in redundancy, resolved by AF.

This condition builds on similar conditions from Kinyalolo (1991); Oxford (2017), and is based on the logic that languages whose agreement alignment is supposed to cross-reference two distinct arguments should show some morphological effect if this fails to happen. As Preminger (2014) argues, failure to Agree often has a morphological signature. My proposal is that this morphological signature appears not just in cases where a probe fails to find a goal, but also in cases where two probes find the same goal. In the latter case, the lower of the two probes must be pronounced as its ‘failed probe’ allomorph, indicating a case of outward sensitive allomorphy.

Note, however, that there is nothing about this proposal that requires the *internal* argument to control agreement on T and Voice except that it is the closest argument. If the φ -probes on T and Voice were relativized for some feature that the external argument had but the internal argument didn’t, the probes on Voice and T could skip the internal argument and cross-reference the external argument instead. Anti-redundancy would still apply, resulting in Agent Focus, but the Agent Focus morpheme would no longer bleed agreement with the external argument. This is observed for K’iche’, where Set B always agrees with a participant regardless of theta role in Agent Focus constructions.

⁸We might worry about the order of morphemes. A general problem for any analysis that relates the Agent Focus morpheme to the head that governs Set A agreement is that Set A is a prefix, while AF is a suffix. I will not discuss morphology extensively, but will assume that valued Set A morphemes can have a different specification for affix-hood compared to the elsewhere form. I will further assume that the status suffix is sensitive to the number of arguments cross-referenced in a clause, which is why it appears as its “intransitive” allomorph when there is Agent Focus. For additional discussion, I refer the reader to Coon (2019).

- (29) In x-**in**-il-ow le ak'al-ab'
 PRON1S PFV-B1S-see-AF DET child-PL
 "I saw the children." (K'iche'; Davies and Sam-Colop 1990, 531)

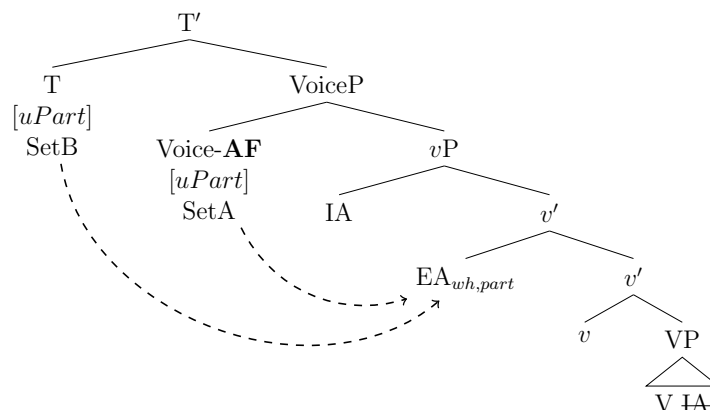

Figure 19: Voice agrees with closest *participant* DP, namely the absolutive marked inner specifier of *v*P. T agrees with the closest absolutive *participant* DP, which is the same inner specifier of *v*P. Set A agreement therefore cross-references the same DP as Set B agreement resulting in redundancy, resolved by AF.

A similar logic derives anti-passive morphology (which is the same in some of these languages as the Agent Focus morpheme). If oblique case can optionally target internal arguments, the external argument is assigned absolutive case and becomes accessible to both Voice and T. Anti-redundancy deletes the lower copy, which gets spelled out as an elsewhere form⁹.

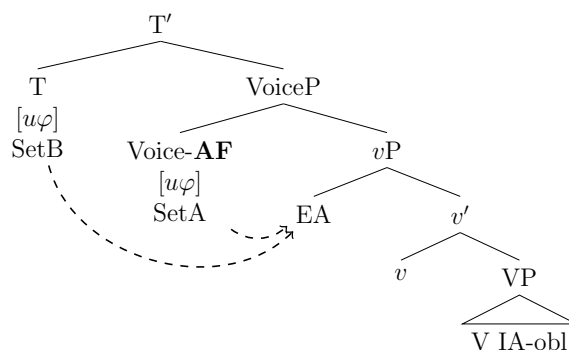

Figure 20: Voice agrees with closest DP, namely the absolutive marked outer specifier of *v*P. T agrees with the closest absolutive marked DP, which is the outer specifier of *v*P.

Languages that have the same AP/AF morpheme are explained because the same mechanism applies to both. This must just be the elsewhere form of Set A. For languages that have different morphemes, both are available in subject extraction, and can be explained if the allomorph is sensitive to which argument's features got deleted.

⁹I have assumed that anti-passive objects stay low because they are inaccessible to *v*'s φ -probe, but that is not a crucial feature of the proposal.

Taking stock, the reason that Agent Focus occurs in subject but not object wh-questions is because subject wh-questions allow the internal argument to raise without bleeding insertion of the external argument. This is because the subject may be licensed by the wh feature on v that is not saturated by the internally merged object. Additionally, object movement in subject wh-questions is possible *whether or not the internal argument normally raises in transitive clauses*. This is because objects in principle always have the option of saturating v 's D feature as long as doing so doesn't bleed insertion of a subject. We entertained the possibility that objects *do* normally move in response to another feature but we could imagine the same facts obtaining in analogous languages with low objects, as is observed elsewhere (see Deal 2016 for a study of diverse languages with EEC effects). This feature of the proposal will be revisited in Section 5.

To summarize, this approach allows us to describe ergative extraction effects in Mayan as a natural by-product of the configuration of φ -probes and Merge features in the language. What is special about the Mayan transitive clause is that transitive agreement alignment is dependent on the outer specifier of vP being marked ergative. Therefore, any derivation involving a transitive clause in which the external argument is *not* assigned ergative should correspond to intransitive agreement alignment, and a special morpheme to prevent one argument's features from getting exponed multiple times.

The source of Agent Focus is non-homogeneous in the sense that multiple derivations can result in two adjacent probes agreeing with the same argument. On the other hand, the featural makeup of each head in a transitive clause *is* homogeneous across these constructions. Transitive clauses, object wh-questions, and subject wh-questions are built from the same set of functional projections with the same set of features. What differs across these constructions is the features of the arguments. This stands in contrast with approaches that propose a non-homogeneous account of Mayan transitive clauses, in which Agent Focus constructions involve a distinct flavor of v or Voice¹⁰.

Our work isn't done, however, because there are conditions under which subject extraction does *not* require special morphology in these languages. On this approach, we hope that these conditions affect the featural makeup of the arguments in such a way as to result in transitive agreement alignment despite the presence of wh-features on the subject. We will see that this prediction is generally borne out.

3.1 Subject extraction without special morphology

There are three environments in which a subject may extract without Agent Focus or antipassive morphology (Coon et al., 2019, and references there): 1) Multiple fronting, 2) NP objects, and 3) Reflexives/extended reflexives. I will show that each of these environments corresponds to a different derivation than canonical subject extraction, thus resulting in regular transitive agreement alignment.

¹⁰Ranero (2019) presents independent evidence from voice mismatches under sluicing in Kaqchikel that suggests regular transitive clauses and AF constructions are homogenous, because active-AF mismatches are allowed under sluicing. Assuming these facts are generally true across the family, it is empirical support for my proposal that transitive clauses and AF constructions differ only in agreement mismatches, not lexical or structural ones.

3.1.1 Multiple fronting

Starting with multiple fronting, it has been observed that the order of specifiers at CP determines whether subject extraction requires the Agent Focus construction. SO orders correspond to regular transitive agreement alignment, while OS corresponds to Agent Focus and the lack of Set A.

(30) Multiple extraction (Kaqchikel; García Matzar and Rodríguez Guaján 1997, 405)

a. SOV - no AF

[*subj*Ja ri utiw-a'], [*obj*ja ri aq] x-e-ki-tij
 FOC DET coyote-PL FOC DET pig PFV-B3P-A3P-eat

‘(In contrast to) the coyotes, it’s the pigs they eat.’

b. OSV - AF

[*obj*ja ri aq], [*subj*Ja utiw-a'] x-e-ti-o
 FOC DET pigs FOC coyote-PL PFV-B3P-eat-AF

‘(In contrast to) the pigs, it’s the coyotes that eat them.’

My account has a natural explanation for these facts if we treat the Mayan left periphery as a generalized \bar{A} -position. Assuming that the examples in (30) are derived by true multiple extraction, and that multiple extraction is order preserving (Richards, 1997, Davis, in prep), we expect the order of specifiers at CP to reflect the order of specifiers at vP . The generalization in (30) can therefore be restated as follows.

(31) If the order of specifiers at vP is SO, we get transitive agreement; if the order of specifiers at vP is OS, we get intransitive agreement and Agent Focus.

Observe that the generalization in (31) is simply a restatement of the proposal in this paper that agreement alignment of a transitive clause is sensitive to the order of specifiers at vP . The question is, does the proposal predict both possible orders at vP given two arguments with \bar{A} -features? The answer is yes, depending on which \bar{A} -features the arguments have. If they both have the same \bar{A} -features, the order SO is predicted. If they have different \bar{A} -features (i.e. *top* vs. *foc* vs. *wh*), the order OS is predicted.

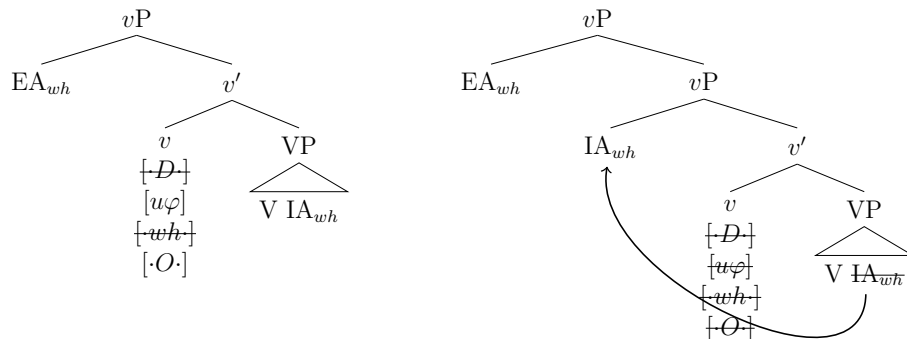

Figure 21: SOV if both arguments have the same features (by the same reasoning as plain transitive clauses- movement of the internal argument has the capacity to bleed insertion of an external argument).

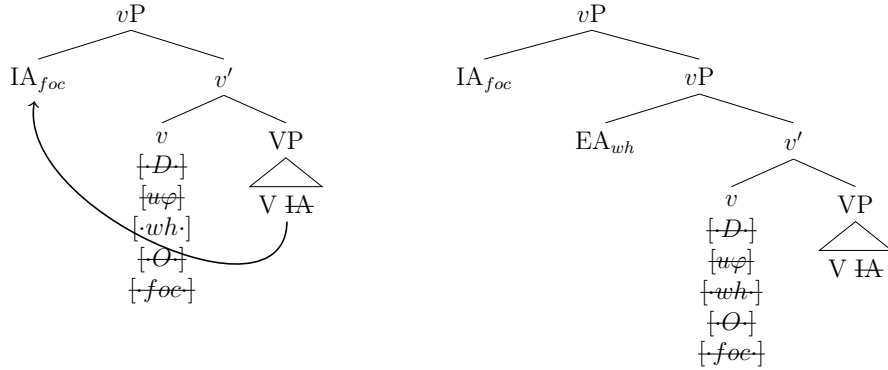

Figure 22: OSV if the two arguments satisfy different features on v , (by the same reasoning as subject wh questions- movement of the object no longer bleeds external Merge).

Since OS order at vP is only predicted when object movement does not bleed external Merge, it can only arise if the subject's features are not a subset of the object's, otherwise we should always get SO order. This predicts that (30a,b) should have slightly different meanings. While in (30a), both fronted arguments should have the same interpretation (focused in this case due to the focus marker ja), in (30b), one of the arguments should be interpreted as topical.

While testing this hypothesis for examples like (30) may be difficult given the available data and translations, there are other cases of multiple fronting that corroborate this view. For example, when both the subject and object are fronted existentials, the presence of Agent Focus corresponds to what seems to be a change in information structure. The truth conditions of (32a,b) should be the same, but are given different translations. This is explained if the object is interpreted as topical in (32b) but not in (32a).

(32) *Kaqchikel* (Erlewine 2016: 14)

- a. K'o k'o x- \emptyset -u-tz'ët
 $\exists \exists$ COM-B3S-A3S-see
 'Someone saw something.' (*There's something that someone saw)
- b. K'o k'o x- \emptyset -tz'et-ö
 $\exists \exists$ COM-B3S-see-AF
 'There's something that someone saw.' (*Someone saw something)

There is debate surrounding the status of the leftmost phrase in multiple fronting constructions, however. Aissen (1992); Pixabaj & England (2011) have argued for a more articulated view of the K'ichee' left periphery in which the left-most nominal is always topical, and the inner phrase is always focal. They also observe a prosodic break between the two fronted nominals, which they analyze as evidence that the topical argument was base generated high, rather than internally merged there. On this view, Coon et al. (2019) argue that the presence or absence of Agent Focus is predictable from whether the subject alone has undergone \bar{A} -movement. In (30a), the subject is base generated as a high topic so the only moving argument is the object, which does not require Agent Focus. In (30b), the object is base generated high, and the subject \bar{A} -moves, which is predicted to have Agent Focus morphology.

A problem for this approach is the fact that the left-most nominal appears to be island sensitive in *Kaqchikel*, suggesting that it has in fact undergone movement. Erlewine (2016)

has shown that while long distance movement of existentials is normally possible in *Kaqchikel*, movement is ruled out when it crosses an island boundary. If the outer specifier in (34b) were base generated high, this sensitivity to islands would be unexpected. The information structure difference in (32a,b) is therefore not the result of the outer specifier in (32b) being a high topic, but rather arises from the fact that a topical DP has moved there.

(33) Baseline: movement of **k'o** from an embedded clause is ok (*Kaqchikel* Erlewine 2016: 17)

- a. K'o n-Ø-noji-n [chin **k'o** yawa']
 ∃ INC-B3S-think-AF that ∃ sick
 'Someone thinks that someone is sick.'
- b. **K'o** k'o n-Ø-noji-n [chin yawa']
 ∃ ∃ INC-B3S-think-AF that sick
 'There is someone that someone thinks is sick.'

(34) Movement out of a relative clause island ruled out (*Kaqchikel* Erlewine 2016: 17)

- a. K'o x-Ø-k'ul-ö [ri achin ri **k'o** x-Ø-u-tz'ët]
 ∃ COM-B3S-meet-AF the man RC ∃ COM-B3S-A3S-see
 'Someone met the man who saw something.'
- b. ***K'o** k'o x-Ø-k'ul-ö [ri achin ri x-Ø-u-tz'ët]
 ∃ ∃ COM-B3S-meet-AF the man RC ∃ COM-B3S-A3S-see
 intended: 'There is something_i that someone met the man who saw it_i.'

In summary, this paper's proposal accounts for the interaction between Agent Focus and word order in multiple fronting examples provided that movement to the left periphery is to a generalized \bar{A} -position. Additionally, both word orders are predicted to be possible depending on expected information structural differences between them. What remains to be investigated is how the predicted featural differences in (30a,b) and (32a,b) result in the proposed focal and topical interpretations discovered by Pixabaj & England (2011). If it is right that the interpretation of a fronted nominal is entirely predictable from its position, this result might lend itself better to a more cartographic view of the left periphery. According to their typology, however, there are four types of interpretations available to fronted nominals, two topical and two focal, which suggests that examples like (30a,b) should be multiply ambiguous. I leave investigation of the full typology to future research.

3.1.2 NP Objects

It has been observed that subject extraction does not require Agent Focus if the object is an NP rather than a full DP.

(35) No AF with NP objects (*K'iche'*; Aissen 2011: 12)

- Jachiin x-u-loq' (*rii) uuq?
 WH PFV-A3S-buy DET cloth
 'Who bought the cloth?'

This is expected on the following assumptions, which predict that NP objects stay in situ and are never the outer specifier of *v*P, but do not disrupt the case properties of transitive clauses.

1. NP's are case competitors
2. NP's are accessible to Agree
3. NP's cannot satisfy the same Merge features as DP's, i.e. [$\cdot D \cdot$] or [$\cdot O \cdot$]

If both DP and NP objects moved to Spec vP , we would either expect v to have two distinct Merge features, one for DP objects and one for NP objects, or we would expect it to have some feature that doesn't care about the category of the XP in merges with. On the former analysis, we should expect to be able to find derivations in which there are three specifiers of vP : an external argument, an NP internal argument, and a DP internal argument (say in a ditransitive). It is not clear that we find this behavior in these or any languages. Likewise, if the Merge feature that triggered object movement did not discriminate, we might expect vP 's with adjuncts to bleed object movement, which has also not been argued to occur.

Therefore, NP's are not expected to move to Spec vP , given that the feature needed to trigger movement of DP objects needs to be of category D. The external argument is therefore predicted to be the only specifier of vP , accessible to the φ -probe on Voice but not on T, which yields transitive agreement alignment.

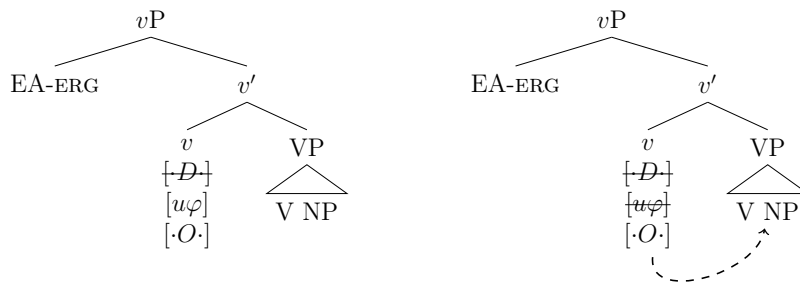

Figure 23: The internal argument now only satisfies v 's φ -probe and nothing else. The order of operators doesn't matter- transitive agreement alignment is predicted.

An additional consequence of this approach is that agreement must adhere to the weak PIC, in which the vP phase is not spelled out until C is merged (Chomsky, 2001). In the proposed configuration, the Set B probe on T and the in-situ NP object are separated by the vP phase boundary. NP objects nevertheless control Set B agreement, which requires the contents of the vP phase to be accessible to the probe on T at some point in the derivation¹¹.

(36) NP complements still control set B (Pascual 2007, Coon et al. 2019))

Ma jun achi taj k-e'-u-b'oq alaj taq chee'
 NEG INDF man IRR INC-B3PL-A3S-uproot DIM PL tree

'It's not a man that is uprooting little trees.' (K'iche'; Aissen 2011, 12, citing López Ixcoy 1997)

¹¹At first glance, it is not clear that (36) contains an NP, rather than a DP object, because the bare plural could have a null determiner. That said, the verb form contains a prefix $k-$, which is glossed as an incorporation morpheme. Assuming noun incorporation is only available to NP's, it seems that Set B can indeed cross reference NP objects.

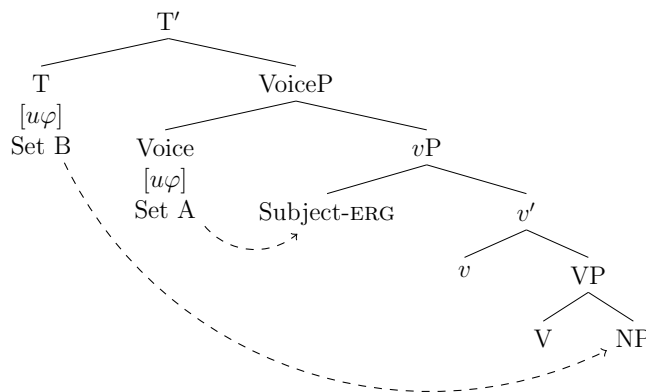

Figure 24: NP's must be accessible the φ -probe on T from within the v P phase.

The weak PIC was originally motivated by a similar phenomenon in Icelandic. In Icelandic, like in English, φ -agreement on the verb is typically correlated with whatever phrase moves to Spec TP. An exception to this rule is when that phrase is marked for quirky case. In that case, agreement instead cross references the nominative marked object, even though it might be in situ below the verb.

(37) *Icelandic* (Sigurðsson 1996: 23)

- a. Henni voru gefnir hattarnir.
her.DAT were.3PL given.PL hat.the.NOM.PL
'She was given the hats.'
- b. *Henni var gefið hattarnir.
her.DAT was.DFT given.DFT hat.the.NOM.PL
intended: 'She was given the hats.'

Icelandic word order is typically very transparent. If the object were to shift across the verb (which it sometimes does), we would observe a word order effect. We can see that it has not shifted in (37) because it is pronounced to the right of the lowest verb. This verb is presumably in situ because there is a higher auxiliary verb that moves to T.

The most straightforward description of Icelandic agreement assumes the existence of a φ -probe and a Merge feature on T. If the element that satisfies the Merge feature proves not to be a suitable φ -goal, the φ -probe must instead be satisfied by something else in T's scope, namely the internal argument. This description requires there to be a stage in the derivation in which T's φ -probe can interact with elements inside the v P domain before the v P phase has been shipped to spell-out. This is precisely what the weak PIC predicts¹².

In summary, there are languages where the internal arguments must be visible to T for agreement in situ. The existence of such languages entails the existence of a theory that describes them, which would presumably allow Mayan finite T to agree with in situ objects as well.

¹²Note that if someone had evidence against the weak PIC, the v phase head is also expected to bear the φ -features of the internal argument because it also has an abstract probe. We could therefore imagine that the φ -features on v could be the target for Agree by T instead of the internal argument.

3.1.3 Reflexives and extended reflexives

The last environment in which subject extraction does not require Agent Focus is when the transitive subject binds into the object. In fact, if Agent Focus is used in these cases, non-coreference between the subject and object is required¹³.

- (38) No AF with Reflexive objects or Extended reflexive objects
- Maktxel max y-il **s-b'a**?
 who PFV A3S-see A3S-self
 “Who saw herself?” (Q’anjob’al; Coon et al. 2014, 225)
 - Maktxel max s-bon **s-na**?
 who PFV A3S-paint A3S-house
 “Who_i painted his_{i/*j} house?” (Q’anjob’al; Coon et al. 2014, 226)
 - Maktxel max bon-on **s-na**?
 who PFV paint-AF A3S-house
 “Who_i painted his_{*i/j} house?” (Q’anjob’al; Coon et al. 2014, 226)

There are two features of (38) that need to be explained: 1) the fact that Agent Focus corresponds to obligatory non-coreference between the subject and object, and 2) the fact that (38a,b) can be derived without Agent Focus. The first puzzle is readily explained by the theory. In Agent Focus constructions, the subject never c-commands the object at any stage of the derivation, and crosses the object when it \bar{A} -moves to Spec CP. This derivation violates Principle A if the object is an anaphor, and violates weak crossover (WCO) if it is coreferent with the subject by any means.

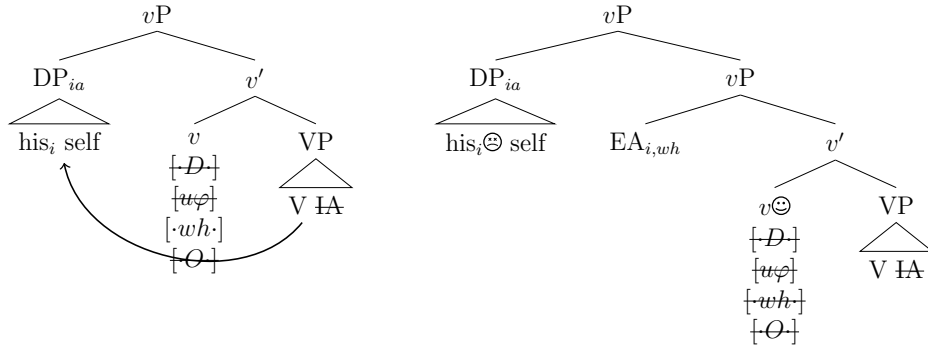

Figure 25: A normal subject wh-question derivation results in Agent Focus because the subject never c-commands the object at any point. Principle A is never satisfied in this derivation.

- (39) [_{CP} Who_i [_{TP} SetB [_{VoiceP} AF [_{vP} his_i house [_{vP} who_i [_{VP} painted his_i house? WCO

Larsen (1987) shows that in K’iche’, there is obligatory non-coreference between the subject and object in an analogous object wh-question (40), which can likewise be explained by WCO. On the present theory, WCO is predicted for both subject and object wh-questions when the

¹³This is only true in languages with distinct AF and AP morphemes. Anti-passives don’t rule out coreference between the subject and object when the subject is extracted.

wh-word is coreferent with the other nominal, because both derivations require the wh-word to move past the other nominal. In an Agent Focus construction, the wh-subject moves past the non-wh-object as in (39), resulting in a WCO violation if the two nominals are coreferent (38c). Object wh-questions are regular transitive derivations, in which the object is the lower specifier of vP , and moves past the subject en route to Spec CP. This again results in a WCO violation if the two nominals are coreferent.

- (40) jachin_i x-Ø-u:-ch'ay ri: r_{j/*i}achala:l
 who PFV-3B-3A-hit the his/her_j-relative
 ‘Who_i did his/her_{j/*i} relative hit?’ (Larsen, 1987, p. 46)

- (41) [_{CP} Wh_{0i} [_{TP} SetB [_{VoiceP} SetA [_{vP} his_i relative [_{vP} wh_{0i} [_{VP} hit wh_{0i}?]]]]]] WCO

The present theory therefore correctly predicts an Agent Focus derivation to converge only if there is no coreference between the subject and the object. This raises an immediate problem, which is that subject wh-questions like (38a,b) seem like they should never be generated. All else being equal, the syntax predicts subject wh-words in (38a,b) to be merged after the object raises, which leads to Agent Focus (and a Principle A violation if the object is an anaphor). Subsequent \bar{A} -movement of the subject leads to a WCO violation because it crosses the coreferent object.

I therefore propose that (38a,b) must not be canonical transitive clauses¹⁴. Following Rodrigues 2010, it is conceivable that the apparently transitive clauses corresponding to (38a,b) are actually derived by possessor raising to a theta position, followed by wh-movement. On this approach, Set A agreement inside the object in (38a,b) cross-references a *trace* rather than a covert possessor. Both transitive theta roles are discharged, but the derivation unfolds as though it were an unaccusative clause.

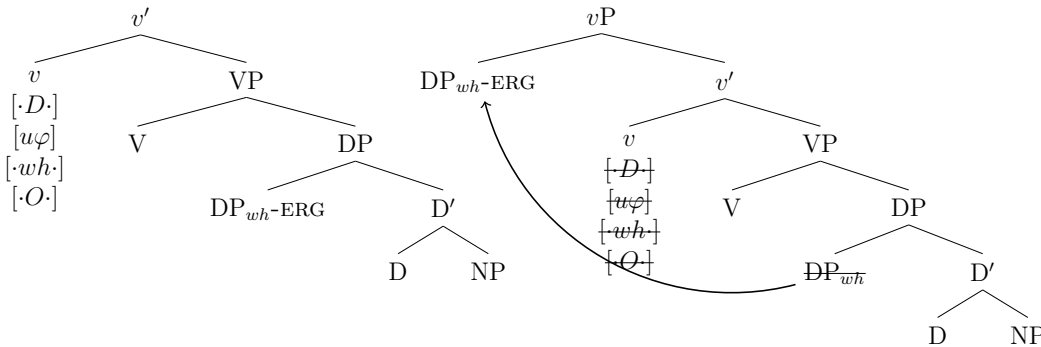
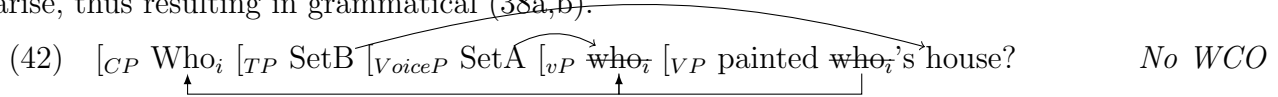

Figure 26: Possessor raising to external argument position: possessor can/must move first because it satisfies all the features on v and needs a theta role (if the clause is to be interpreted as transitive). Internal argument is left in situ (but if it moved, it would have to do so second or else the subject wouldn't c-command its trace).

On this hypothesis, the subject would not be externally merged as the specifier of vP , but would rather be base generated in a possessor position inside the internal argument. If no DP

¹⁴Alternatively, if conditions on the derivation were sensitive to the needs of anaphors and possessive pronouns to be bound, it is conceivable that derivational economy could be exceptionally bled in (38a,b).

is externally merged, the *wh*-marked possessor is internally merged because it satisfies all of the features on *v* (unless *v*'s φ -probe is case discriminating, in which case it only satisfies all the Merge features). Derivational economy therefore predicts the possessor to have to raise to the theta position at *vP* to the exclusion of anything else. Normal *wh*-movement then proceeds¹⁵. This derivation should have the agreement alignment of a transitive clause, and no WCO effects arise, thus resulting in grammatical (38a,b).



To summarize, subject *wh*-questions where the subject binds into the object cannot have an Agent Focus derivation without violating Principle A/WCO. They can, however, be derived via possessor raising, which feeds *wh*-movement.

We have seen that the profile of subject extraction in multiple fronting, NP objects, and reflexives/extended reflexives is straightforwardly predicted by the theory with the addition of two assumptions. First, we must assume that in situ objects are accessible to Agree by finite T (weak PIC). Second we must assume that reflexives and extended reflexives may be optionally derived by possessor raising to a theta position if base generating the subject high would bleed its ability to corefer with the object.

To conclude, special morphology (i.e. AF/AP) is predicted to occur if the outer specifier of *vP* is marked absolutive, and is therefore accessible to both higher φ probes. The outer specifier of *vP* is only expected to be absolutive if 1) the internal argument is marked oblique, or 2) the internal argument moves before the subject is externally merged. These two scenarios correspond to anti-passive and normal extraction of a transitive subject respectively. However, if a transitive object has other properties that rule out movement to Spec *vP*, for example because no feature would license it (NP objects) or because doing so would violate Principle A/WCO, then only one specifier of *vP* is predicted, namely the ergative subject. Under such circumstances, the agreement alignment of the clause is expected to be that of a normal transitive clause, whether or not the subject is \bar{A} -extracted.

The subject-object asymmetry in \bar{A} -extraction that we have seen therefore boils down to competition between DP's at the *vP*-level. The argument that satisfies *v*'s D feature always controls agreement on Voice (in a transitive clause), which might get exponed or deleted depending on whether that argument is also accessible to T¹⁶. Many factors impact the determination of which argument satisfies *v*'s D feature, which is why the profile of Agent Focus is so varied across constructions.

There is one environment in which Agent Focus is found but doesn't bleed any agreement, which is puzzling for many accounts, this one included. For some reason, embedded non-finite clauses always require AF in Q'anjob'al, and are called the "crazy anti-passive" (43). What is puzzling for my account isn't necessarily the presence of AF, or the fact that AF doesn't bleed agreement with the subject, but rather the presence of the morpheme glossed as Set B.

¹⁵Note that the object can still control set B agreement if it is plural for example, which makes them pattern like NP objects on my account.

¹⁶We do not expect to see Agent Focus/anti-passive morphology in adjunct extraction because adjuncts cannot satisfy *v*'s D feature (unless they are nominal adjuncts). They therefore are never expected to affect the order of DP specifiers at the edge of *vP*, and should not affect the general agreement alignment of the clause. This prediction is borne out. Some adjuncts independently cooccur with a post-verbal particle *wi* when pronounced preverbally, but none of them disrupt agreement or require Agent Focus/antipassive morphology (see Henderson 2007 for discussion).

- (43) Chi uj [hach y-il-**on**-i]
 IPFV be.able.to B2S A3S-see-AF-ITV
 “She can see you.” (Q’anjob’al; Coon et al. 2014, 180)

Recall that AF elsewhere in the language was the result of both T and Voice agreeing with the same argument. In a non-finite clause, however, we expect there not to be a φ -probe corresponding to Set B at all, so anti-redundancy should never apply. We therefore expect to see Set A pronounced on Voice (which we do), and no other agreement morphology because there is no finite T, and v ’s φ -probe doesn’t normally have an exponent.

That said, since AF was proposed to be an elsewhere form, it is conceivable that it appears in other environments, for example if a probe fails or if an agreement slot on the verb has no referent. It could be that Q’anjob’al inserts the AF morpheme, not because anti-redundancy applies, but simply because the verb is missing a morpheme because of the structurally impoverished environment and requires an elsewhere form.

This approach would explain the presence of Set A agreement and AF, but we would expect AF to bleed Set B agreement. This isn’t borne out if we take the gloss in (43) at face value. However, the status of the morpheme *hach* isn’t terribly clear in this example. It has been glossed as Set B because it is the form of the second person clitic in the language, which is very similar to the morpheme that attaches to agreeing verb stems *-ach*. However, as a standalone morpheme, it need not be analyzed as the product of agree. It could simply be that the embedded verb selected for a pronominal argument, which is morphosyntactically a clitic. This is incidentally the form of the pronoun in copular clauses.

- (44) Coon et al. (2014): 48

Kuywom **hach**.
 student 2S

‘You are a student.’

More needs to be learned about these examples to determine whether they pose a serious problem to the theory, given that several features of their structure are debated. For instance, Coon et al. (2014) propose that embedded non-finite clauses in Q’anjob’al are actually nominalized forms and therefore deserve a different explanation altogether. I leave this as a topic for future research.

4 Comparison with previous analyses

I have argued that the movement/agreement correlation in Romance and the movement/anti-agreement correlation in Mayan are two sides of the same coin, so to speak. In Romance, the order of Merge and Agree affects whether the *object* is accessible to Agree, due to the position of φ probes and timing of case assignment. In Mayan, the organization of probes and the case alignment are different, so the order of Merge and Agree affects whether the *subject* is accessible to Agree. The logic of the proposal is that features on v , and on the arguments themselves, have consequences for the order of operations, which in turn affects the structural orientation of arguments in the clause.

I assume that while the orientation of arguments affects which arguments are accessible for Agree, it does not affect whether an argument can be subsequently \bar{A} -extracted. This is because I assume \bar{A} -movement to be non-local in the standard sense; no matter how many non-wh-elements structurally intervene between C and a wh-element, that wh-element should be accessible for \bar{A} -extraction.

- (45) \bar{A} -movement is insensitive to intervening nominals
- a. $[_{CP} \text{Who } [_{TP} \text{T } [_{vP} \text{DP}_{int} [_{vP} \text{who } [_{VP} \text{ate } \text{DP}_{int}]]]]]$?
- b. $[_{CP} \text{What } [_{TP} \text{T } [_{vP} \text{DP}_{ext} [_{vP} \text{what } [_{VP} \text{ate } \text{what}]]]]]$?

The profile of this approach is different from other approaches in the literature in several ways. I will discuss the logic of some other analyses now and argue that the present theory is not only empirically successful, but is also better equipped to describe the typology of languages with and without EEC effects. A prominent way in which this analysis differs from others pertains to the status of the star in (23).

- (22) Maktxel max-ach il-**on**-i?
 who PFV-B2S see-AF-ITV
 “Who saw you?” (Q’anjob’al; Coon et al. 2014, 213)
- (23) *Maktxel max y-il ix ix?
 who PFV A3S-see CLF woman
 intended: “Who saw the woman?” (Q’anjob’al; Coon et al. 2014, 193)

The present theory treats (22) as the output of the normal derivation of a subject wh-question. In that sense, the star in (23) exists because the grammar never generates a derivation that corresponds to the agreement alignment in (23) when the subject is a wh-phrase. A distinct, but logically possible treatment of the star in (23) assumes that the default derivation of a subject wh-question *should* correspond to (23), but that there are language specific constraints on the grammar that rule it out. Analyses that make this choice refer to the contrast in (22) and (23) as a *ban on ergative extraction*, thus presupposing that (23) corresponds to an LF that should exist under normal circumstances but is filtered out.

On these approaches, Agent Focus in (22) “rescues” the language from a total lack of subject wh-questions by providing an alternative construction in which the subject may extract without violating the relevant conditions on the grammar. Any theory of this sort must therefore 1) propose grammatical constraints that are violated in (23), 2) include a structural description of a novel construction (i.e. the Agent Focus construction), and 3) provide a theory that regulates the distribution of this construction so it only appears when the subject is \bar{A} -extracted.

Most existing analyses of Mayan Agent Focus indeed posit a ban on ergative extraction, based on the assumption that wh-questions are universally derived from clauses that look like their non-wh counterparts. More explicitly, they presuppose the existence of an input to (23) that looks like (46), and propose that something goes wrong in the subsequent transformation into a subject wh-question.

- (46) Max y-il-a’ maktxel ix ix.
 ASP A3S-see-TV who CLF woman

intended: ‘Who saw the woman.’ (pre wh-movement)

Most analyses that I know of consider two possible sources for the failure to derive (23) from (46): 1) general conditions on \bar{A} -movement, 2) the effects of ergativity on \bar{A} -movement or case licensing. Some proposals of these kinds are considered below.

1. Proposed conditions on \bar{A} -movement

- Assuming objects c-command the subject in high absolutive Mayan languages, the subject must move across the object en route to Spec CP, which violates some version of the PIC (Coon et al., 2014).
- Assuming subjects move to Spec TP in Mayan, subsequent movement to Spec CP is too short to count as a licit operation (Erlewine, 2016).
- Wh-movement in Mayan is sensitive to intervening nominals. Assuming objects c-command the subject in high absolutive Mayan languages, the subject is invisible to the \bar{A} -probe and cannot extract (Coon et al., 2019).

2. Proposed effects of ergativity on \bar{A} -movement

- \bar{A} -extraction of an ergative subject bleeds absolutive assignment on the object because movement of the subject involves a case checking operation that should have checked the features of the object (Assmann et al., 2015).
- Wh-probes can be case discriminating in some languages, in which case the ergative subject is inaccessible to the relevant \bar{A} -probe (Deal, 2016).

According to these approaches, Agent Focus constructions represent a novel transitive construction in which either 1) objects stay low (i.e. out of the way so the subject doesn’t move across it), 2) a derivation in which the subject moves from a different position, which bleeds agree, or 3) a construction that doesn’t assign ergative case. Typically, a last-resort condition is required to block Agent Focus constructions unless the subject has to undergo \bar{A} -extraction.

The diversity of previously proposed assumptions about Mayan and the mechanics of \bar{A} -movement/case assignment is too great to adequately describe here. What these approaches all have in common, however, is a general problem of cross-linguistic appeal. By assuming that (22) and (23) necessarily correspond to two novel derivations made available by UG, these proposals enrich the typology of possible constructions across languages, and the types of constraints that can govern them. The theory therefore requires significant elaboration to explain why, for example, we don’t observe a corresponding ban on accusative extraction in many languages, or why \bar{A} -movement behaves one way in some languages and another way in others, or why only languages with an extraction ban have extra intransitive constructions¹⁷.

The approach outlined in this paper, by contrast, assumes the existence of one unique way to derive subject wh-questions in a given language, which in Mayan corresponds to (22).

¹⁷There are also approaches to Mayan Agent Focus that do not rely on a ban on ergative extraction, but treat Agent Focus morphology as an effect of pronunciation. For example, Baier (2018) proposes that some φ -probes simply cannot expone the φ -features of a wh-phrase. He formulates an impoverishment rule that applies when a probe tries to agree with a wh-subject. This line of reasoning has the advantage that it doesn’t posit a distinct Agent Focus construction in the language, but it seems hard to predict more generally which languages should have such an impoverishment rule.

According to this theory, Agent Focus is not a novel construction and thus does not need to be regulated. Moreover, this theory has the advantage that it makes a natural comparison between unrelated language families such as Romance and Mayan, which takes into account more than just the case alignment of each.

The force behind the proposal is the conjecture that the derivation in (46) is not necessarily available in every language, not because language specific constraints or case properties might rule it out, but because UG generally dictates an order of operations that is sensitive to the features of arguments. As we will see in Section 5, the space of possible cross-linguistic variation is clearly defined by the system, and may naturally extend to observations about EEC effects in other languages.

5 The cross-linguistic outlook

This paper has argued for a view of Mayan EEC effects in which EEC effects in principle should have a non-homogeneous source across languages. What gives rise to AF in high absolutive Mayan languages is not just that objects might move, not just that the language has object agreement, nor the mere fact that the language is ergative, but rather a combination of the case alignment, movement and agreement properties of the languages in question.

This non-homogeneity of the AF morphology in Mayan is evident from the treatment of subject wh-questions and anti-passives. These two constructions are morphologically similar, despite being derivationally distinct, because they both feed anti-redundancy in a similar way. We now turn our attention to low absolutive Mayan languages, and more generally, languages with a different distribution of probes and arguments to evaluate the predictions of this framework. We will also revisit the relevance of object movement to the predictions of the theory.

Following the description from Coon et al. (2014), I assume that low absolutive Mayan languages are much like their high absolutive counterparts, except that objects stay low and Set B agreement is on *v* instead of T. These languages' *v* should therefore look like Romance *v* in that their only A-features are 1) a D feature for introducing the external argument, and 2) a φ -probe for controlling Set B.

Recall that for a regular transitive clause, external Merge must necessarily precede agreement with the object because the subject's features constitute a subset of the object's: operating on the object first would bleed insertion of the subject. By contrast, if the subject is a wh-phrase, it can merge late by satisfying a separate wh-feature. However, as we saw for Romance, derivational economy does not tell us whether to agree and move first, or to externally merge first in this case, thus incorrectly predicting optional PPA in subject wh-questions. This is because both internal Merge and external Merge satisfy the same number of features, and neither operation checks a proper subset of the other's features. Internal Merge satisfies the D feature and φ -probe; external Merge satisfies the D feature and the wh-feature.



(a) Internal Merge satisfies two features on v : (b) External Merge satisfies two features on $[u\varphi]$ and $[·D·]$. If internal Merge applies first, v : $[·wh·]$ and $[·D·]$. If external Merge applies first, no internal Merge \rightarrow no AF.

Figure 27: Derivational economy doesn't tell us whether external or internal Merge should be the first operation, predicting AF to be optional in subject extraction contexts.

For Romance, the choice of whether to merge or move affects case on the object, which in turn determines whether PPA is realized. In low absolutive Mayan languages, objects are always accessible to Agree because they are absolutive, so the choice of whether to merge or move affects whether anti-redundancy applies. If internal Merge applies before external Merge, the higher probe will agree with the object, as did the lower probe, resulting in AF. If external Merge applies before internal Merge, the higher probe will agree with the subject, resulting in regular transitive agreement.

On this view, movement of the object in high absolutive languages is not crucial to deriving Agent Focus, because there exists a derivation in low absolutive languages that should give rise to the same morphological effect. Movement of the object is only crucial for making Agent Focus *obligatory* in high vs. low absolutive languages by making the derivation in Figure 27a non-optional. However, if there were an independent feature of the system that generally decided between Figures 27a and 27b in a given language, Agent Focus could be obligatory in some languages and absent in others, even if the object never moved in normal transitive clauses.

Given that we never see optional AF in low absolutive Mayan, or optional PPA in Romance subject wh-questions, it seems that there is indeed some additional feature of the system responsible for choosing derivation 27b in these cases. A central question for future investigation pertains to whether the relevant condition is general or parametric across languages. In some ways it is very natural to suppose that, when given the choice between internal and external Merge, the derivation would generally choose to introduce its arguments as soon as possible. This follows the *Merge-over-Move* (MoM) logic considered by Chomsky (1995) to explain the distribution of expletives in some languages. What is special about the framework presented in this paper is that this tendency towards external Merge is bled by derivational economy if the object satisfies *more* features on v than a wh-subject would.

Alternatively, it could be that the choice to merge early in low absolutive Mayan and Romance is due to a parameter setting, rather than a general MoM constraint. On this approach, there could be languages that are featurally identical to these, in which subject extraction corresponds to obligatory AF or PPA, because the derivation always chooses to move first (Figure 27a).

Deciding between these approaches would require a cross-linguistic investigation of low-object languages and subject extraction that is outside the scope of this paper. What is

important is that EEC effects are not in principle ruled out in languages with low objects/object agreement. Whether EEC effects are observable in low object languages depends on the features on v and the choice between derivations in Figure 27. In fact, Deal 2016 discusses extensive evidence that low absolutive languages may indeed have EEC effects, which is in line with the present proposal. Additionally, this is predicted *irrespective of the case alignment of the language*. In principle, we could imagine a nominative language, whose objects and object agreement are low, that chooses to internally merge first before merging a wh-subject. Such a language would have special morphological effects in subject extraction, despite not being ergative.

This is desirable outcome. While EEC effects have traditionally been considered to only occur in ergative languages, the case alignment of some languages with purported EEC effects is debated. Standard assumptions that EEC effects only occur in ergative languages have led many to analyze Austronesian languages as having ergative alignment (e.g. DeGuzman 1988; Aldridge 2004), for example. However, I refer the reader to Chen (2017); Erlewine et al. (2017) for arguments that some of the languages in question are in fact nominative. Erlewine et al. (2017) also discuss similar extraction patterns in Dinka Bor, which is also argued to be a nominative language. On my account, EEC effects and nominative case alignment are not mutually exclusive. Future research would examine the distribution of probes in these languages and consider the particular morphological effects of each relevant construction to test the predictions of the present theory.

While case alignment is not predicted to be crucial for EEC effects in *low* object agreement languages, it is more relevant when object agreement is high. Let us consider a hypothetical language that is identical in every respect to Q'anjob'alan languages except it is nominative-accusative. We predict that regular transitive clauses in this language should always look anti-passive. The outer specifier of vP would be the subject for reasons we have already seen, and it would be accessible to both Voice and T because it is unmarked for case. Anti-redundancy applies, resulting in agreement that cross-references the subject plus an elsewhere form instead of object agreement (indistinguishable from a language with subject but not object agreement except for the additional AP morpheme).

Unless this language had another functional projection that could attract the object to a position between Voice and T, it looks generally impossible for this language to both be nominative and have object agreement, making the presence of one of the probes effectively vacuous (why would someone learn it?). EEC effects would also look suspiciously like the regular transitive clause, except that the object might be the agreement controller. The fact that EEC effects are linked to ergativity in high object languages is therefore not intrinsically related to ergativity, but can be attributed to a natural sparsity of nominative languages in the relevant paradigm¹⁸.

¹⁸Labrador Inuttut may be a rare case of a nominative language whose φ -probes are both above the subject. Johns (2001); Yuan (2018)'s work on microvariation in the Inuit language family shows that there are varying degrees of ergativity across the family. Some languages look robustly ergative, where overt case marking appears on transitive subjects and agreement alignment looks high absolutive. Others, however, vary on this spectrum. One language among them, Labrador Inuttut, is proposed to have mostly lost its ergativity due to the fact that its regular transitive clauses look anti-passive by default, which is expected on the present proposal. Apparently, ergative agreement alignment reappears when the object is a pronoun that shifts to a position higher than the subject. On my view, as long as this position is above the probe that is associated with subject agreement (seems likely given Yuan (2018)'s diagnostics- object clitics are proposed to move quite high), the higher probe should agree with the object and the lower one should agree with the subject, bleeding anti-redundancy, and

To summarize, whether or not a subject wh-question corresponds to special morphology is proposed to be tied to whether in a given language, subject wh-phrases can be externally merged late. Factors that affect the timing of external Merge include the features on v and the features on the arguments. Factors that affect the profile of the observed morphological effects of subject extraction include case assignment and the distribution of φ -probes. Case assignment does not affect *whether* morphological effects should be observed, however, unlike standard assumptions about these effects.

Subject extraction may therefore cooccur with special morphology in both ergative and nominative languages. However, nominative languages carry some intrinsic restrictions on where φ -probes can be generated so that multiple arguments are cross-referenced, which limits the domain in which we can investigate these phenomena to languages with low object agreement¹⁹.

6 Conclusion

This paper drew a comparison between the movement-agreement correlation in Romance and the movement-anti-agreement correlation in high absolutive Mayan languages, and offered a unified theory of both patterns. The central insight of the paper is that the order of Merge and Agree at vP is not fixed for a given construction or language, but rather depends on the featural makeup of v and its arguments. Which operation applies first affects the structural orientation of arguments, and has consequences for Agree.

In most transitive constructions, the subject satisfies a subset of the features on v that the object could, which leads to a derivation in which external Merge precedes any other operation at the vP -level. If the subject is a wh-phrase, however, external Merge might not apply early because other operations no longer necessarily bleed theta role assignment. The potential for the subject to merge late just in case it has additional features was proposed to account for the effects of subject extraction in high absolutive Mayan languages.

revealing an otherwise hidden possibility of object agreement.

- (1) *Labrador Inuttut* (Johns 2001)

Margarita Kuinatsa-i-juk **Ritsati-mik**
Margarita.ABS tickle-AP-3S.S Richard-MOD

‘Margarita is tickling Richard.’

The profile of Agree in the language is otherwise not noticeably different from its high absolutive cousins, making it conceivable that Labrador Inuttut is a good candidate for Q’anjob’al-2. The probes are all high (Yuan argues they are actually higher than Voice and T), but the case alignment is flipped. The fact that this change corresponds to an extra morpheme in transitive clauses is predicted by the theory. What is missing from the paradigm is evidence from wh-movement in the language. Other languages in the Inuit family have been shown to have ergative extraction effects only in relative clauses, preferring the anti-passive in subject relatives. If this pattern extends to Labrador Inuttut, then subject relatives should look like normal transitive clauses.

¹⁹While this paper explored the effects of subject wh-movement on agreement, the proposed system makes potentially more general predictions about subject vs. object extraction, which should be explored. In particular, in many languages where arguments move to Spec TP, subsequent \bar{A} -extraction of those arguments is correlated with complementizer-trace effects (Perlmutter 1968, see Erlewine 2020, Pesetsky, to appear for discussion). Two features of the present analysis are relevant here: 1) the order of specifiers at vP affects which arguments might move to Spec TP, and 2) if \bar{A} -extraction corresponds to a probe on C, any argument that satisfied a probe on T that is subsequently probed by C should cause an anti-redundancy violation.

In the relevant Mayan languages, the features on v are such that internal Merge is the preferred first operation (satisfies derivational economy), *unless* internal Merge would bleed external Merge. Transitive clauses instantiate the exceptional case in which external Merge must precede internal Merge. However, subject wh-questions are not exceptional in this way, and thus correspond to a derivation in which external Merge *follows* internal Merge (wh-subjects are independently licensed by [$\cdot wh \cdot$]). This has the effect of making the object the most accessible φ -goal to higher probes. While the apparent promotion of the object was not proposed to have consequences for subject \bar{A} -extraction, it was proposed to have consequences for Agree, resulting in the agreement alignment observed in Agent Focus constructions.

On this view, Agent Focus constructions are not logically intransitive, but are functionally identical to transitive clauses. The apparent difference between them lies in the addition of the wh-feature on the subject, which switches the order of arguments at Spec v P. The reversal of the order of specifiers makes the object a target for both φ probes, which is expounded as one agreement morpheme plus the Agent Focus morpheme. The Agent Focus morpheme was analyzed as the elsewhere form of the φ -probe which would normally target the external argument.

The logic of this approach is very different from existing proposals regarding the morphological effects of subject extraction. Many approaches attribute such morphological effects to special properties of \bar{A} -movement or case assignment in the relevant languages. The present analysis, by contrast, makes no new assumptions about the nature of \bar{A} -movement, and treats the case properties of the Agent Focus constructions as epiphenomenal from the derivation of a subject wh-question.

References

- Aissen, Judith. 1992. Topic and focus in Mayan. *Language* 68(1). 43–80.
- Aissen, Judith. 2011. On the syntax of Agent Focus in K'ichee'. In Kirill Shklovsky, Pedro Mateo Pedro & Jessica Coon (eds.), *Proceedings of famli*, MIT Working Papers in Linguistics.
- Aldridge, Edith. 2004. *Ergativity and word order in Austronesian languages*. Ithaca, NY: Cornell University dissertation.
- Assmann, Anke, Doreen Georgi, Fabian Heck, Gereon Müller & Philipp Weisser. 2015. Ergatives move too early: On an instance of opacity in syntax. *Syntax* 18. 343–387.
- Baier, Nico. 2018. *Anti-agreement*. Berkeley, CA: University of California, Berkeley dissertation.
- Bobaljik, Jonathan D. 2008. Where's phi? agreement as a post-syntactic operation. In *Phi theory*, Oxford: Oxford University Press.
- Branigan, Philip. 1996. Verb-second and the a-bar syntax of subjects. *Studia Linguistica* 50(1). 50–79.
- Can Pixabaj, Telma. 2004. *La topicalización en K'ichee': una perspectiva discursiva*. Guatemala: dissertation.

- Can Pixabaj, Telma. 2015. *Complement and purpose clauses in K'iche'*. Austin, TX: University of Texas Austin dissertation.
- Chen, Victoria. 2017. *A reexamination of the Philippine-type voice system and its implications for Austronesian primary-level subgrouping*: University of Hawai'i at Mānoa dissertation.
- Chomsky, Noam. 1991. Some notes on economy of derivation and representations. In R. Freidin (ed.), *Principles and parameters in comparative grammar*, 417–454. Cambridge, MA: MIT Press.
- Chomsky, Noam. 1993. A minimalist program for linguistic theory. In K. Hale & S. Keyser (eds.), *The view from building 20*, 1–52. Cambridge, MA: MIT Press.
- Chomsky, Noam. 1995. *The minimalist program*. Cambridge, MA: MIT Press.
- Chomsky, Noam. 2000. Minimalist inquiries: The framework. In R. Martin, D. Michaels & J. Uriagereka (eds.), *Step by step: Essays on minimalist syntax in honor of Howard Lasnik*, 89–155. MIT Press.
- Chomsky, Noam. 2001. Derivation by phase. In Michael Kenstowicz (ed.), *Ken Hale: A life in language*, 1–52. Cambridge, MA: MIT Press.
- Coon, Jessica. 2019. Building verbs in Chuj: Consequences for the nature of roots. *Journal of Linguistics* 55(1). 35–81.
- Coon, Jessica, Nico Baier & Theodore Levin. 2019. Mayan Agent Focus and the Ergative Extraction Constraint: Facts and fictions revisited. <https://ling.auf.net/lingbuzz/004545>.
- Coon, Jessica, Pedro Mateo Pedro & Omer Preminger. 2014. The role of case in A-bar extraction asymmetries. *Linguistic Variation* 14(2). 179–242.
- Deal, Amy-Rose. 2016. Syntactic ergativity: Analysis and identification. *Annual Review of Linguistics* 2. 165–185.
- DeGuzman, Videia P. 1988. Ergative analysis for Philippine languages: an analysis. In Richard McGinn (ed.), *Studies in austronesian linguistics*, 323–345. Ohio University Press.
- Déprez, Viviane. 1998. Semantic effects of agreement: The case of French participle agreement. *Probus* 10(1). 1–67.
- Erlewine, Michael Yoshitaka. 2016. Anti-locality and optimality in Kaqchikel Agent Focus. *Natural Language & Linguistic Theory* 34(2). 429–479.
- Erlewine, Michael Yoshitaka, Theodore Levin & Coppe van Urk. 2017. Ergativity and Austronesian-type voice systems. In Jessica Coon, Diane Massam & Lisa Travis (eds.), *The handbook of ergativity*, Oxford: Oxford University Press.
- Johns, Alana. 2001. An inclination towards accusative. *Linguistica Atlantica* 23. 127–144.
- Kayne, R. S. 1989. Null subjects and clitic climbing. In O. Jaeggli & K. J. Safir (eds.), *The null subject parameter*, 239–262. Dordrecht, Holland: Kluwer Academic Publishers.

- Kinyalolo, Kasangati K.W. 1991. *Syntactic dependencies and the Spec-Head agreement hypothesis in Kilega*. Los Angeles, CA: unpublished University of California, Los Angeles dissertation.
- Larsen, T. W. 1987. The syntactic status of ergativity in Quiche. *Lingua* 71. 33–59.
- Longenbaugh, Nicholas. 2019. *On expletives and the agreement-movement correlation*. Cambridge, MA: MIT dissertation.
- Merchant, Jason. 2013. Voice and ellipsis. *Linguistic Inquiry* 44(1). 77–108.
- Müller, G. 2010. On deriving CED effects from the PIC. *Linguistic Inquiry* 41(1). 35–82.
- Oxford, Will. 2017. Inverse marking as impoverishment. In Aaron Kaplan, Abby Kaplan, Miranda K. McCarvel, & Edward J. Rubin (eds.), *Proceedings of the 34th west coast conference on formal linguistics*, 413–422. Cascadilla Proceedings Project, Somerville, MA, USA.
- Pesetsky, David. 2000. *Phrasal movement and its kin*. The MIT Press.
- Pesetsky, David & Esther Torrego. 2001. T-to-C movement: Causes and consequences. In Michael Kenstowicz (ed.), *Ken Hale: A life in language*, 355–426. Cambridge, MA: MIT Press.
- Pixabaj, Can & Nora England. 2011. Nominal topic and focus in K'ichee'. In Rodrigo Guitérrez-Bravo, Line Mikkelsen & Eric Potsdam (eds.), *Representing language: Essays in honor of Judith Aissen*, 15–30.
- Pollock, J.-Y. 1989. Verb movement, universal grammar, and the structure of IP. *Linguistic Inquiry* 20(3). 365–424.
- Preminger, Omer. 2009. Breaking agreements: Distinguishing agreement and clitic doubling by their failures. *Linguistic Inquiry* 40(4). 619–666.
- Preminger, Omer. 2014. *Agreement and its failures*. The MIT Press.
- Ranero, Rodrigo. 2019. Voice mismatches in Kaqchikel sluicing: Consequences for syntactic parallelism. *To appear in proceedings of WSCLA 24* .
- Rezac, Milan. 2013. Case and licensing: evidence from ECM+DOC. *Linguistic Inquiry* 44(2). 299–319.
- Richards, Norvin. 1997. *What moves where when in which language?* Cambridge, MA: MIT dissertation.
- Richards, Norvin. 2012. Uttering theory. Ms. MIT.
- Rodrigues, Cilene. 2010. Possessor raising through thematic positions. In Norbert Hornstein & Maria Polinsky (eds.), *Movement theory of control*, 119–146. *Linguistik Aktuell*, John Benjamins.
- Tada, Hiroaki. 1993. *A/A-bar partition in derivation*. Cambridge, MA: MIT dissertation.

- van Urk, Coppe & Norvin Richards. 2015. Two components of long-distance extraction: Successive cyclicity in Dinka. *Linguistic Inquiry* 46(1). 113–155.
- Vázquez Álvarez, Juan J. 2011. *A grammar of Chol, a Mayan language*. Austin, TX: University of Texas Austin dissertation.
- Yuan, Michelle. 2018. *Dimensions of ergativity in Inuit: Theory and microvariation*: Massachusetts Institute of Technology dissertation.